



# Storage & Reception

Aspirational Design Meets Functional Solutions



# Contents

## Modular Solutions

Rover® Range.....	8
Rhodes Modular Shelving .....	12

## Mobiles

Tempo.....	18
Axis.....	20
EkoSystem .....	22

## Tambour & Credenzas

Tempo.....	26
Axis.....	30
Axis Caddy .....	34
EkoSystem .....	36
Rover® Range .....	38
Rhodes Modular Shelving .....	42

## Cupboards, Bookcases & Filing Cabinets

Axis.....	48
Axis Caddy .....	56
EkoSystem .....	60
Rover® Range .....	72

## Lockers

Axis.....	78
Knox.....	80
Rover® Range .....	84

## Reception

Anvil.....	88
Axis.....	90

# First Impressions Refined

From precision-built reception counters to modular storage, each element is crafted for performance and harmony.



Storage and Reception solutions designed to welcome, organise and endure. The Blue Ink Group Storage & Reception range is designed to deliver just that. Seamlessly coordinated finishes and thoughtful detailing bring balance and order to every workspace.

- A Anvil Reception
- B Tempo Sliding Door Credenza with Planter Box
- C Rhodes Modular Shelving
- D Avalon Armchair
- E Avalon 2-Seater
- F Sora Nesting Coffee Table

# Modular Solutions

Design that greets you.

Modular shelving and storage solutions bring adaptability to any office space, making it easy to define zones with efficiency and clarity. Designed to enhance surroundings through simplicity and style, these systems elevate both function and aesthetics. With flexible configurations and effortless mobility, they move with your team and your needs.

A Rhodes Modular Shelving





# Rover® Range



## Refine, Reconfigure, Rover.

Each piece in the Rover Range features large medical-grade castors for easy movement and reconfiguration, perfect for adaptable workspaces. Locking mechanisms keep the furniture stable once positioned. With multifunctional items like double-sided glass whiteboards, mobile TV cabinets, and credenzas, you can tailor the space to your needs. Real timber accents and acoustic panelling add a natural, calming touch, enhancing productivity.

The Rover Range combines mobility, style, and flexibility, offering a versatile solution for modern, collaborative work environments

Timber sourced from a FSC Certified Forest

# Rover® Range

Product Details



## Features

### FSC-Certified Timber Frame:

Real timber accents from FSC-certified sources add a touch of nature to any space.



### Acoustic & Pinnable Recycled Board:

Enhance your workplace acoustics with our recycled acoustic board panels with a high Noise Reduction Coefficient (NRC) rating of 0.35

### Large Medical Grade Castors:

Experience effortless mobility with large medical-grade castors, designed for smooth, reliable movement and easy reconfiguration of spaces.

### Aluminium Handles:

Benefit from the sleek durability of Aluminium handles, combining modern aesthetics with long-lasting performance.

### Soft-close Hinges:

Enjoy a quieter, more refined user experience with soft-close hinges that prevent slamming and ensure smooth operation.

### Adjustable Shelving:

Optimise your storage space with adjustable shelving, allowing for flexible organisation tailored to your needs.

## Colours On-Hand

### Stocked & Styled



White & Maple Hardwood

### Stocked & Styled Castors



White & Grey

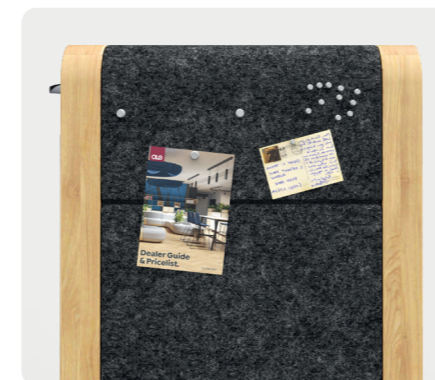

Plants are not included •

## Product Details

**A**



**Mobile Credenza**  
W900 X H920 mm

**B**

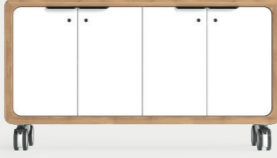

**Mobile Credenza**  
W1650 X H920 mm

**C**



**Mobile Cupboard**  
W900 X H1320 mm

**D**



**Mobile Whiteboard Small**  
W900 X H1620 mm

**E**



**Mobile Whiteboard**  
W900 X H1920 mm

**F**



**Mobile Seat**  
W800 X H470 mm

**G**



**Mobile Locker**  
W900 X H1620 mm

**H**



**Mobile Half Locker-Half Bookcase**  
W900 X H1920 mm

**I**



**Mobile Bookcase Small**  
W900 X H1620 mm

• Plants are not included

## Product Details

**J**



**Mobile Bookcase Large**  
W900 X H1920 mm

**K**



**Mobile Rubbish Bin**  
W900 X H1920 mm

**L**



**Mobile Planter Small**  
W900 X H1620 mm

**M**



**Mobile Planter Large**  
W900 X H1920 mm

**N**



**Mobile TV**  
W1358 X H1620 mm

**O**



**Mobile TV**  
W1358 X H1920 mm

### Take a closer look

The Rover Range offers a versatile palette of Colour options designed to complement any interior aesthetic. To explore the full Colour selection speak with your [Customer Partnership Manager](#).





# Rhodes

## Modular Shelving



### Transform your space.

Designed for effortless assembly and limitless reconfiguration, Rhodes enables you to create dynamic, functional zones with a light-filled, open feel. Integrate natural elements seamlessly and transition between spaces with ease.

Whether you're zoning, storing or adding some greenery, Rhodes brings versatility and visual impact in equal measure.

GECA Certification Available by request.

# Rhodes Modular Shelving

Product Details



### Features

#### Stability:

Well placed castors that enable easy manoeuvrability without compromising on function or safety.

#### Compatibility:

A perfect pairing to the Klass, Agile, Anvil and Axis desk ranges.

#### Stylish Design:

Slimline under-desk practical storage with a refined, modern look, the perfect choice for a flexible, uncluttered office aesthetic.

#### Space Saver:

Designed for tight workspaces featuring curved edges for a softer, contemporary profile. This compact pedestal provides functional storage without sacrificing style.

#### Finish & Inclusions:

Durable metal with 2 drawers and 1 file drawer, with single suspension file arm.

### Colours On-Hand

#### Stocked & Styled



New Oak Ravine  
Nordic Maple

#### Powdercoat



Black

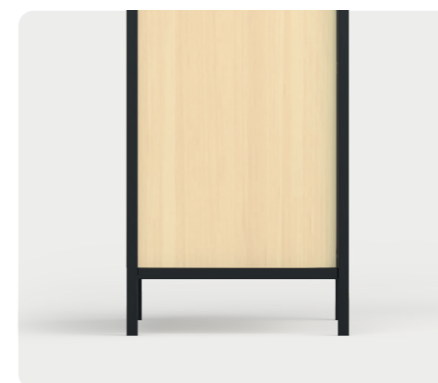

# Rhodes Modular Shelving

Plants are not included •

## How to configure

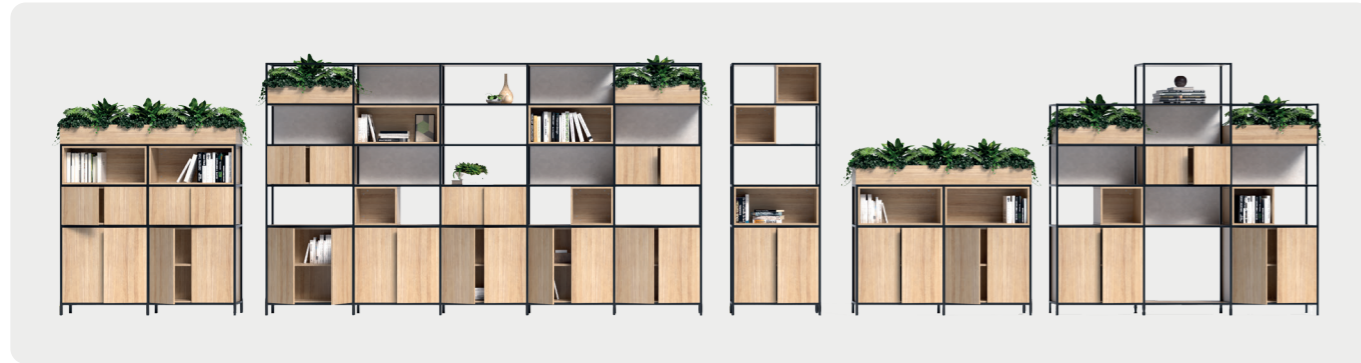

### Step 1 Choose your frame height

Select from four heights: 1234mm, 1617mm, 2000mm, or 2383mm. Each frame is 840mm wide and 400mm deep.



### Step 2 Choose your frame width

Configure your layout by adding frames side by side. Start with a single bay or scale up to suit your space, add 820mm for each additional bay. Each frame includes standard shelving.

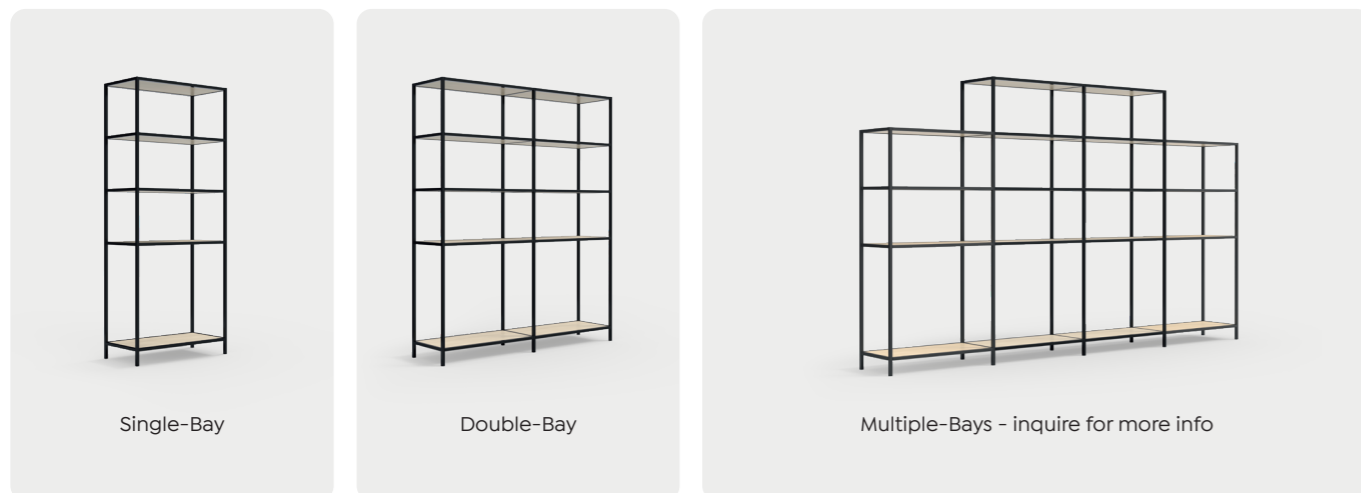

# Rhodes Modular Shelving

Plants are not included •

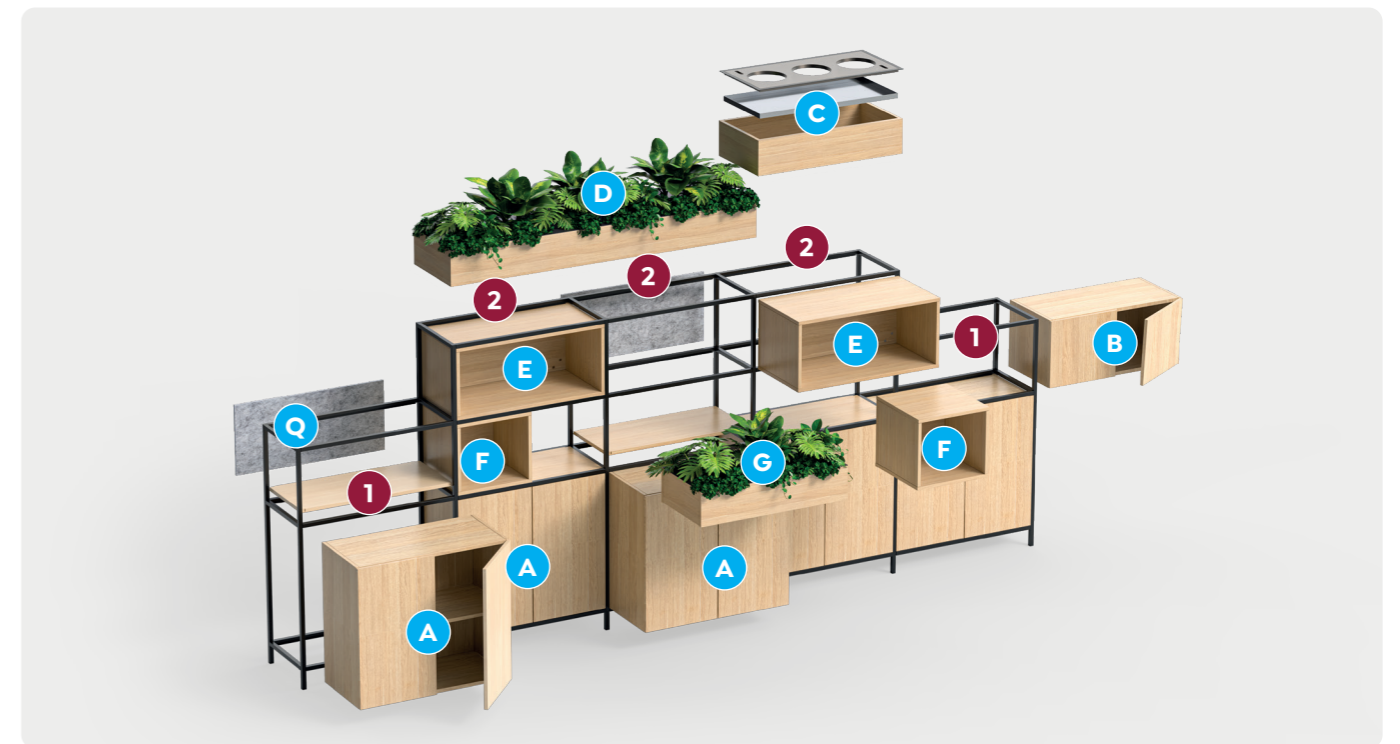

### Step 3 Select your components

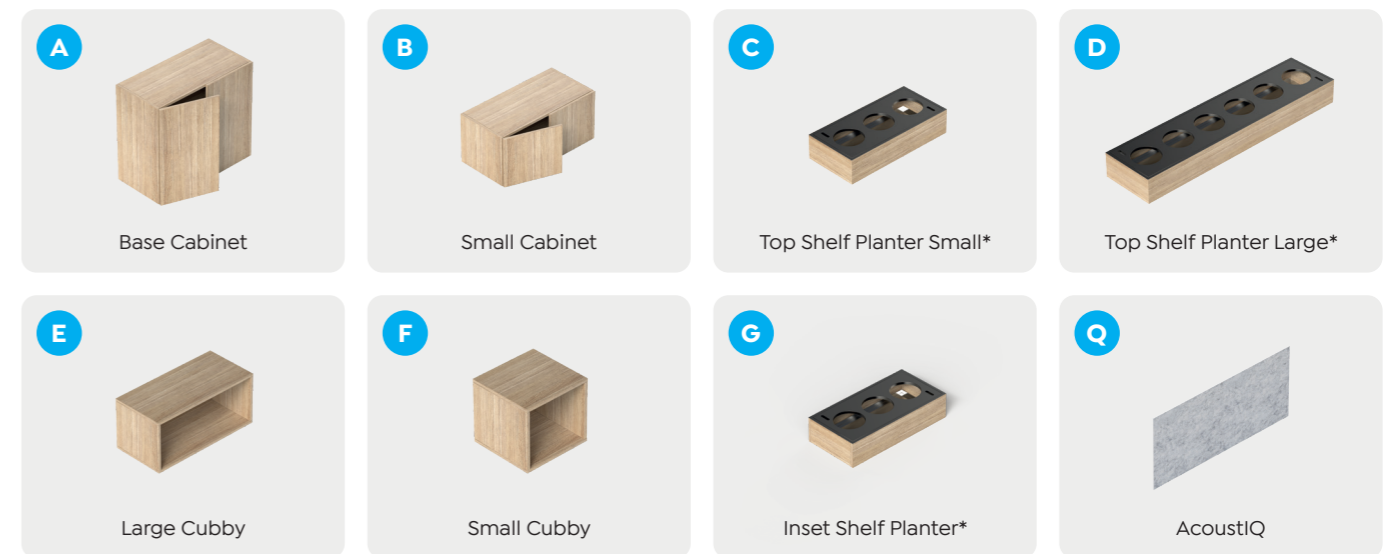

### Sample Configuration



Designed for open-plan environments, our mobile storage range delivers cohesive aesthetics and everyday practicality. Our mobile units blend clean design with robust construction. Crafted with simplicity and durability, each unit keeps personal belongings safe, organised, and always within reach, ideal for offices, collaborative zones, and breakout spaces.



# Mobiles

Seamless Mobility. Timeless Design.

- A Engage Chair
- B AcoustIQ Zen Screens
- C Klass Double Sided Desk
- D Tempo Sliding Door Credenza with Planter Box
- E AcoustIQ Sonos Panel
- F Tempo Mobile



# Tempo Mobile



## Refined, flexible storage for contemporary workplaces.

Compact and versatile, the Tempo Mobile Pedestal is the perfect under-desk storage solution for individual workstations. Its slim profile keeps essentials close at hand while maintaining a clean, uncluttered workspace.

Available in classic white or black graphite, Tempo blends smart design, natural elements, and everyday efficiency to suit the modern office.

# Tempo Mobile

## Product Details



Tempo Mobile Regular



Tempo Mobile Narrow Round Edge



Tempo Mobile Narrow

## Features

### Stability:

Well placed castors that enable easy manoeuvrability without compromising on function or safety.

### Compatibility:

A perfect pairing to the Klass, Agile, Anvil and Axis desk ranges.

### Finish & Inclusions:

Durable metal with 2 drawers and 1 file drawer, with single suspension file arm.

### Stylish Design:

Slimline under-desk practical storage with a refined, modern look, the perfect choice for a flexible, uncluttered office aesthetic.

### Space Saver:

Designed for tight workspaces featuring curved edges for a softer, contemporary profile. This compact pedestal provides functional storage without sacrificing style.

## Dimensions

	Regular	Narrow	Narrow Round Edge
Width	390 mm	300 mm	300 mm
Depth	450 mm	450 mm	450 mm
Height	600 mm	600 mm	592 mm

## Colours On-Hand

### Stocked & Styled



Black Graphite



Classic White





# Axis Mobile.



## Organised Efficiency.

The Axis Mobile is a versatile unit essential for every workstation. It features two stationary drawers and a large filing drawer.

With ball-bearing extension runners and gang locks, this mobile unit ensures your possessions are secure while keeping your workspace neat. The built in anti-tilt system adds stability, making it a reliable choice for any office environment.

GECA Certification Available by request.

# Axis Mobile

Product Details



**Axis Mobile Drawers**  
Two Box Drawers + One File Drawer - Gang Locking



**Axis Mobile Drawers**  
Four Box Drawers - Gang Locking

## Features

### Stability:

Well placed castors that enable easy manoeuvrability. A fifth wheel on mobile drawers for added stability.

### Compatibility:

A perfect pairing to the Klass, Agile, Anvil and Axis desk ranges.

### Finish & Inclusions:

Only available in White. Three and Four drawer option with pen tray included.

### Stylish Design:

Slimline under-desk practical storage with a refined, modern look, the perfect choice for a flexible, uncluttered office aesthetic.

### Security:

Gang-locking drawers. Keyed differently by default, however, keyed alike is available on request.

## Dimensions

Variants	2 Drawers + 1 File	4 Drawers
Overall Width	400 mm	400 mm
Overall Depth	500 mm	460 mm
Overall Height	600 mm	600 mm

## Colours On-Hand

Stocked & Styled



White





# EkoSystem Mobile.



## Simple Design. Universal Appeal.

The EkoSystem Mobile Drawer Unit is available in charcoal or white melamine on E1-grade substrate with matching PVC edges. It offers two configurations: 2 drawers plus 1 file drawer or a 4-drawer option. Equipped with five castors for stability and ball bearing extension runners for smooth operation, this unit ensures both durability and ease of use. Its versatile design and quality materials make it an excellent addition to any workspace.

# EkoSystem Mobile

Product Details



**EkoSystem Mobile Drawer Unit**  
1 File & 2 Box Drawers



**EkoSystem Mobile Drawer Unit**  
4 Box Drawers

## Features

### Stability:

Equipped with five castors for stability and ball bearing extension runners for smooth operation, this unit ensures both durability and ease of use.

### Compatibility:

A perfect pairing to the Klass, Agile, Anvil and Axis desk ranges.

### Stylish Design:

Slimline under-desk practical storage with a refined, modern look, the perfect choice for a flexible, uncluttered office aesthetic.

### Construction Materials:

18 mm white or charcoal melamine on E1 grade substrate with matching PVC edge

### Finish & Inclusions:

Charcoal or White. Durable, with 2 drawers and 1 file drawer and a 4 drawer option.

## Dimensions

Variants	2 Drawers + 1 File	4 Drawers
Overall Width	400 mm	400 mm
Overall Depth	500 mm	460 mm
Overall Height	600 mm	600 mm

## Colours On-Hand

Stocked & Styled

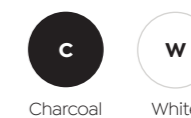

# Tambour, Credenzas & Filing Cabinet

Where Organisation meets Expression.

Blue Ink Group's Tambours & Credenzas transforms everyday organisation into a design statement. Each piece is part of an integrated system, elegant in proportion, practical in use and enduring in quality. With coordinated finishes, and flexible configuration options, this collection brings a sense of unity and aesthetic practicality to dynamic workplaces.



- A Tempo Sliding Door Credenza with Planter Box
- B Tempo Mobile
- C Motion Sync
- D Tempo Tambour Cabinet
- E Klass Double Sided Desk
- F Rhodes Modular Shelving



# Tempo Tambour



## Refined, flexible storage for contemporary workplaces.

A sleek storage solution for files, documents, and office essentials. The Tempo Tambour features smooth-sliding tambour doors to save space and is available in classic white or textured gunmetal black, complementing any office interior.

Add a natural element to office spaces with the Tempo Planter Box, designed to sit atop storage units or credenzas. It softens the office aesthetic and helps enhance collaborative environments.

Available in classic white or black graphite, Tempo blends smart design, natural elements, and everyday efficiency to suit the modern office.

# Tempo Tambour

Product Details

- Plants are not included



Tempo Tambour Cabinet  
Regular



Tempo Tambour Cabinet  
Tall



Tempo Tambour Cabinet  
Wide

## Features

### Improve Aesthetics & Wellbeing:

This dual-function cabinet provides ample storage, while the integrated planter top supports biophilic design.

### Finish & Inclusions:

Available in classic white or textured gunmetal black, with 2 adjustable shelves complementing any office interior.

### Stylish Design

A sleek storage solution for files, documents, and office essentials. The Tempo Tambour features smooth-sliding doors to save space.

### Stability:

Solid design that enables function, form and safety. The unit is lockable and includes adjustable feet for levelling within the workspace.

## Colours On-Hand

### Stocked & Styled

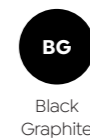

Black  
Graphite

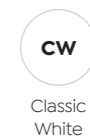

Classic  
White

## Dimensions

Variants	Regular	Tall	Wide
Overall Width	900 mm	900 mm	1200 mm
Overall Depth	450 mm	450 mm	450 mm
Overall Height	1020 mm	1200 mm	1020 mm





# Tempo Credenza



## Refined, flexible storage for contemporary workplaces.

The Tempo Sliding Door Credenza delivers generous storage with a minimal footprint. Its sliding doors allow easy access while maintaining a sleek, modern appearance, perfect for storing documents, samples, and office essentials.

It's the ideal finishing touch at the end of a desking pod, adding both function and visual continuity.

Available in classic white or black graphite, Tempo blends smart design, natural elements, and everyday efficiency to suit the modern office.

# Tempo Credenza

Product Details

- Plants are not included



Tempo Sliding Door Credenza  
Regular



Tempo Sliding Door Credenza  
Wide

## Features

### Improve Aesthetics & Wellbeing:

This dual-function cabinet provides ample storage, while the integrated planter top supports biophilic design.

### Stylish Design:

A sleek storage solution for files, documents, and office essentials. Features smooth-sliding doors to save space.

### Look & Style:

Sliding door credenzas bring generous storage and a minimal footprint, the perfect finishing touch for desking pods.

### Stability:

Solid design that enables function, form and safety. The unit is lockable and includes adjustable feet for levelling within the workspace.

## Colours On-Hand

### Stocked & Styled

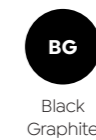

Black Graphite

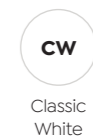

Classic White

## Dimensions

Variants	Regular Credenza	Wide Credenza
Overall Width	900 mm	1530 mm
Overall Depth	450 mm	450 mm
Overall Height	1020 mm	1020 mm





# Axis Tambour

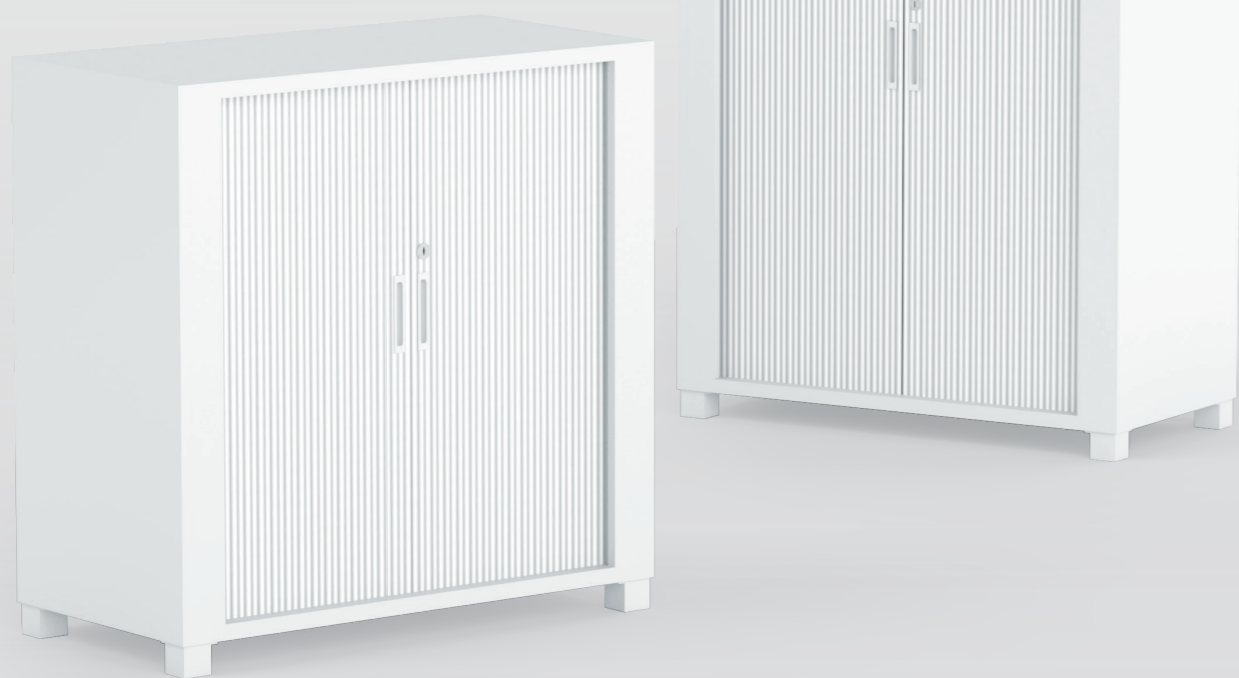

## Organised Efficiency

Available in both low and high configurations, this unit offers an excellent shared storage solution. It features eight adjustable shelves, secure locking doors, and optional planter boxes to introduce biophilic elements into the space.

Designed for efficiency, it includes space-saving roller doors and adjustable feet for easy levelling. The construction is flush-joined with 25mm tops and bases, and 18mm sides and shelves for a clean, durable finish.

GECA Certification Available by request.

# Axis Tambour

Product Details



**Axis Tambour Cabinet**  
1 x 18 mm adjustable shelf Locking



**Axis Tambour Cabinet**  
2 x 18 mm adjustable shelves Locking

## Features

### Compatibility:

A perfect pairing to the Klass, Agile, Anvil and Axis desk ranges.

### Options & Finishes:

Low and high options available. options available. White powdercoat 50 50 mm steel feet with levelling guides. Optional planter boxes available.

### Stylish Design:

Space saving storage with a refined, modern look, the perfect choice for a flexible, uncluttered office aesthetic.

## Dimensions

	Two-Levels	Three-Levels
Width	900 mm	900 mm
Depth	450 mm	450 mm
Height	900 mm	1250 mm

## Colours On-Hand

Stocked & Styled



White

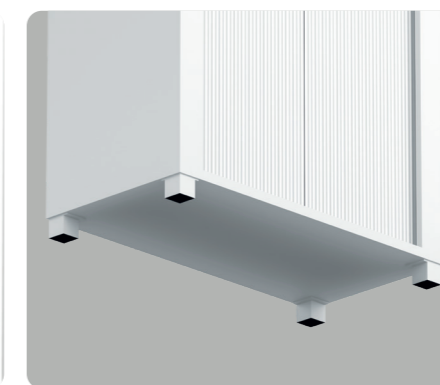
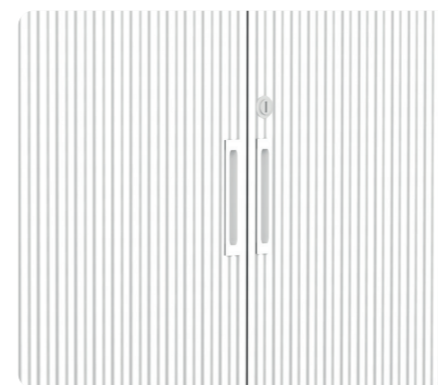



# Axis Credenza



## Organised Efficiency.

The Axis Two-Level Credenza delivers a stylish, practical storage solution designed for shared office environments. Available in 1200mm and 1800mm widths, it provides two generous levels of storage to help keep workspaces organised and clutter-free.

Constructed with 25 mm tops and bases, and 18 mm sides and shelves in white melamine on an E0-grade substrate with matching PVC edging, the credenza offers durability with a clean, contemporary finish. A flush-joined design and white powder-coated steel feet, with levelling glides for easy adjustment, enhance both stability and visual cohesion.

Versatile and refined, the Axis Two-Level Credenza is built to support modern workspace needs with efficiency and style.

GECA Certification Available by request.

# Axis Credenza

Product Details



**Axis Credenza Two Door**  
1 x 18 mm adjustable shelves 2x hinged locking doors



**Axis Credenza Four Door**  
1 x 18 mm adjustable shelves 4x hinged locking doors

## Features

### Stylish Design:

Space saving practical storage with a refined, modern look, the perfect choice for a flexible, uncluttered office aesthetic.

### Compatibility:

A perfect pairing to the Klass, Agile, Anvil and Axis desk ranges.

### Options & Finishes:

White powdercoat 50x 50 mm steel feet with levelling guides. Optional planter boxes available.

## Dimensions

Variants	Two Door	Four Door
Width	1200 mm	1800 mm
Depth	400 mm	400 mm
Height	900 mm	900 mm
Door Width	578 mm	438 mm

## Colours On-Hand

Stocked & Styled



White





# Axis Caddy Mobile



## Organised Efficiency.

The Axis Caddy Mobile delivers a stylish, practical storage solution designed for shared office environments.

Constructed with 25 mm tops and bases, and 18 mm sides and shelves in white melamine on an E0-grade substrate with matching PVC edging, the credenza offers durability with a clean, contemporary finish. A flush-joined design and white powder-coated steel feet, with levelling glides for easy adjustment, enhance both stability and visual cohesion.

Versatile and refined, the Axis Caddy Mobile is built to support modern workspace needs with efficiency and style.

GECA Certification Available by request.

# Axis Caddy Mobile

Product Details



Axis Caddy Mobile  
2 x Drawer Insert



Axis Caddy Mobile  
2 x Tambour Insert

## Features

### Stability:

Well placed castors that enable easy manoeuvrability without compromising on function or safety.

### Compatibility:

A perfect pairing to the Klass, Agile, Anvil and Axis desk ranges.

### Finish & Inclusions:

All drawer and tambour units are interchangeable and include a gang lock to keep your belongings safe. Shelves are height adjustable for even more flexibility and customisation within the unit.

## Dimensions

Variants	2 x Drawer Insert	2 x Tambour Insert
Width	994 mm	460 mm
Depth	460 mm	460 mm
Height	640 mm	640 mm

## Colours On-Hand

Stocked & Styled



White





# EkoSystem Credenza



## Simple Design Universal Appeal.

The Ekosystem Credenza offers a refined, functional storage solution for any workspace. Crafted from 18 mm studio white or new oak/charcoal melamine on an E1-grade substrate with matching PVC edges, it delivers durability with a clean contemporary finish. Adjustable shelves provide flexible organisation, and the unit is designed for fast, straightforward assembly.

Available in two widths, 1200mm and 1600mm, the Ekosystem Credenza brings versatile, streamlined storage to your office environment.

GECA Certification Available by request.

# EkoSystem Credenza

Product Details



EkoSystem Credenza  
Regular 1200 mm



EkoSystem Credenza  
Wide 1600 mm

## Features

### Simple Design:

Practical storage with the perfect blend of functionality, durability and universal appeal.

### Compatibility:

A perfect pairing matches worktop height of 720mm.

### Space Saver:

Designed for tight workspaces with space saving sliding doors.

### Finishes:

Charcoal/New Oak or All White Melamine.

### Certification:

GECA Certification available upon request.

## Dimensions

	Regular	Wide
Width	1200 mm	1600 mm
Depth	400 mm	400 mm
Height	720 mm	720 mm

## Colours On-Hand

### Stocked & Styled

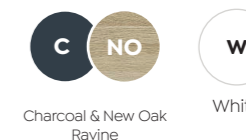



# Rover® Range Credenza



## Refine, Reconfigure, Rover.

A fusion of aspirational design and functionality designed to transform your workspace into a dynamic, adaptable environment.

Each piece is meticulously crafted with large medical-grade castors and acoustic elements, enabling a quieter, more focused environment and timber accents from FSC-certified sources adds a touch of natural elegance, making each piece both functional and stylish.

Timber sourced from a FSC Certified Forest

# Rover® Range Credenza

Product Details



## Features

**FSC-Certified Timber Frame:**  
Real timber accents from FSC-certified sources add a touch of nature to any space.



**Acoustic & Pinnable Recycled Board:**  
Enhance your workplace acoustics with our recycled acoustic board panels with a high Noise Reduction Coefficient (NRC) rating of 0.35

**Large Medical Grade Castors:**  
Experience effortless mobility with large medical-grade castors, designed for smooth, reliable movement and easy reconfiguration of spaces.

**Aluminium Handles:**  
Benefit from the sleek durability of Aluminium handles, combining modern aesthetics with long-lasting performance.

**Soft-close Hinges:**  
Enjoy a quieter, more refined user experience with soft-close hinges that prevent slamming and ensure smooth operation.

**Adjustable Shelving:**  
Optimise your storage space with adjustable shelving, allowing for flexible organisation tailored to your needs.

## Colours On-Hand

Stocked & Styled



White & Maple  
Hardwood

Stocked & Styled Castors



White & Grey



## Dimensions

Variants	No Planter	With Planter
Mobile Credenza	W900 X H920 mm	W900 X H1220 mm
Mobile Credenza + Planter	W1650 X H920 mm	W1650 X H1220 mm
Mobile Rubbish Bin	W1670 X H1220 mm	-



# Rover® Range Credenza

## Product Details



Mobile Credenza  
W900 x H920 mm



Mobile Credenza  
W1650 x H920 mm



Mobile Credenza + Planter  
W900 x H1220 mm



Mobile Credenza + Planter  
W1650 x H1220 mm

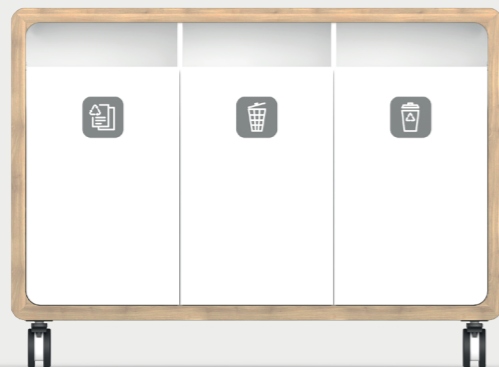

Mobile Rubbish Bin  
W1670 x H1220 mm



- A Cedar 2-Seater Sofa
- B Sora Coffee Table Outer Nesting
- C Sora Coffee Table Inner Nesting
- D Cedar Armchair



# Rhodes

## Modular Shelving



### Transform your space.

Designed for effortless assembly and limitless adaptability, the Rhodes range offers a stylish, configurable solution for modern workspaces. Whether you're looking to create functional zones or display essentials with flair, Rhodes delivers the ultimate in flexibility.

GECA Certification Available by request.

# Rhodes Modular Shelving

Product Details



### Features

#### Certified Quality & Sustainability:

Configurable to customise for any space, meeting diverse storage needs including credenzas, cubbies and cabinets.

#### Durable Construction:

Powder-coated steel frame with melamine shelving for long-lasting use. Ensure perfect levelling with adjustable feet on every surface.

#### Customisable Configurations:

Configure your layout by adding frames side-by-side. Start with a single bay or scale up to suit your space. Each frame includes standard shelving.

#### Finish Options :

Two stylish colour palettes of New Oak Ravine and Nordic Maple.

### Colours On-Hand

#### Stocked & Styled



#### Powdercoat

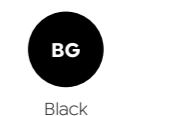

### Dimensions

Variants	No Planter	With Planter
Credenza + Base & Small Cabinet	W840 x H1234 mm	W840 x H1234 mm
Credenza + Base & Small Cabinet + Planter	W1680 X H1234 mm	W1680 X H1234 mm
Rhodes Credenza	W840 X H1234 mm	-



# Rhodes Modular Shelving

## Product Details

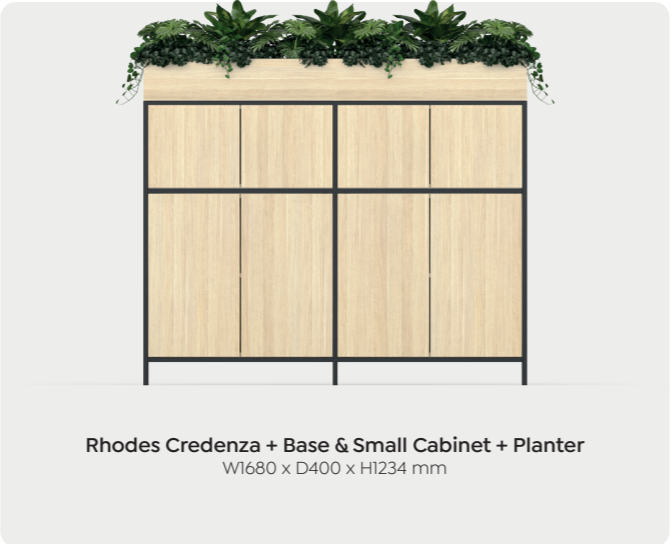
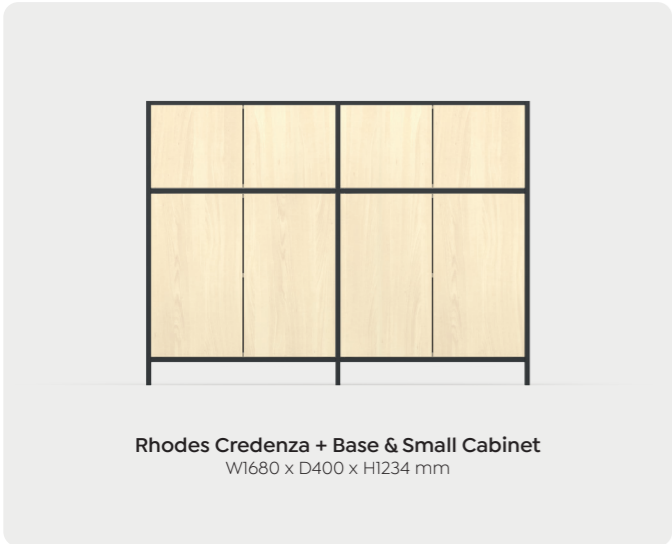
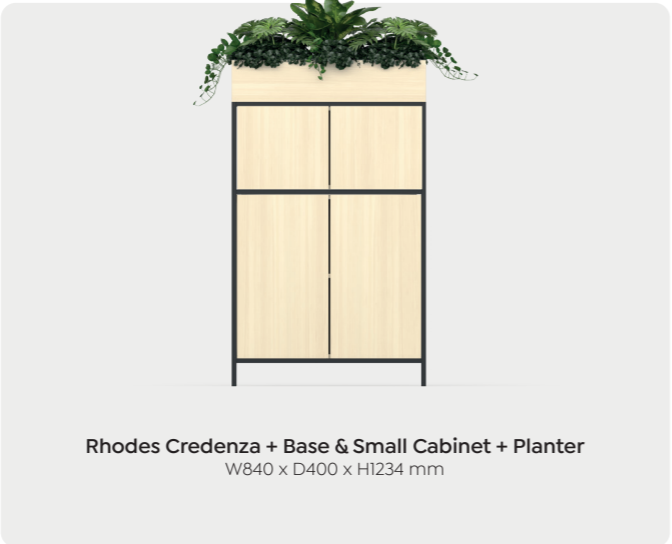
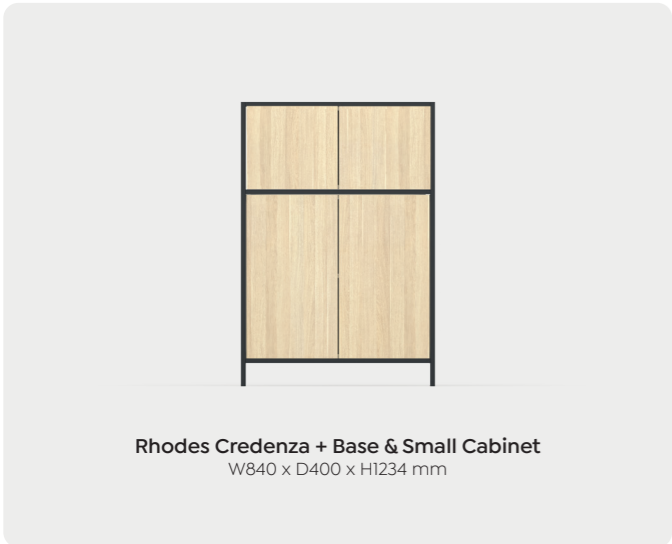

A Okamura Abilis Executive Task Chair

B Modulus Table



# Cupboards, Bookcases & Filing Cabinet

Effortless organisation.

From cupboards and bookcases to secure filing solutions, create a workspace that's organised, efficient, and effortless. Thoughtfully designed for commercial settings, these storage solutions offer durability, flexibility, and a cohesive look while keeping essentials close at hand.

**A** AgileMotion+ Round Double Sided Desk

**B** Tempo Mobile Narrow Rounded

**C** Axis Tower Filing Cabinets

**D** Axis Cupboards Locking Five Levels

**E** Okamura Portone Smart

**F** Axis Tower Bookcase Five Levels



# Axis Cupboard



## Organised Efficiency

The Axis Locking Cupboard delivers dependable shared storage for busy workplaces. Built with 25 mm tops and bases, and 18 mm sides and shelves in white melamine on an E0-grade substrate, it features matching PVC edging for a polished, long-lasting finish.

A flush-joined construction and white powder-coated steel feet, with glides for easy levelling, ensure stability and a refined, cohesive look. Available in three or five-level configurations, the Axis Locking Cupboard offers secure, efficient storage that integrates seamlessly into any modern workspace.

GECA Certification Available by request.

# Axis Cupboard

Product Details



Axis Cupboard Locking  
Three Levels



Axis Cupboard Locking  
Five Levels

## Features

### Construction Materials:

18 mm studio white melamine on E0-grade substrate with matching PVC edge for a long-lasting finish.

### Functional Design:

A flush-joined construction and white powder-coated steel feet, with glides for easy levelling.

### Compatibility:

Efficient storage that integrates seamlessly into any modern workspace.

## Dimensions

Variants	Three Levels	Five Levels
Width	900 mm	900 mm
Depth	400 mm	400 mm
Height	1250 mm	1800 mm

## Colours On-Hand

Stocked & Styled





GECA Certification Available by request.

# Axis Tower Bookcase

Product Details

# Axis Tower Bookcase



## Organised Efficiency

The Axis Tower Bookcase offers practical, streamlined storage with two height-adjustable shelves, providing ample space for books, binders, and everyday essentials. Its clean, contemporary design pairs seamlessly with the wider Blue Ink Group range, supporting a cohesive workplace layout.

Once assembled, the unit measures W506 x D460 x H1250 mm and is supported by white powder-coated steel feet with levelling glides for added stability and easy adjustment across different surfaces.

A versatile and refined addition to any workspace, the Axis Tower Bookcase delivers both style and functionality.

## Features

### Construction Materials:

18 mm studio white or new oak/charcoal melamine on E1-grade substrate with matching PVC edge, 5mm MDF backing board.

### Functional Design:

Two height-adjustable shelves, with white powder-coated steel feet with levelling glides for added stability and easy adjustment across different surfaces.

### Compatibility:

Contemporary design pairs seamlessly with the wider Blue Ink Group range, supporting a cohesive workplace layout.

## Dimensions

Variants	Bookcase/Drawer/ Tambour	Bookshelf 3 Levels	Bookshelf 5 Levels
Width	506 mm	900 mm	900 mm
Depth	460 mm	430 mm	430 mm
Height	1250 mm	1250 mm	1800 mm

## Colours On-Hand

Stocked & Styled



White

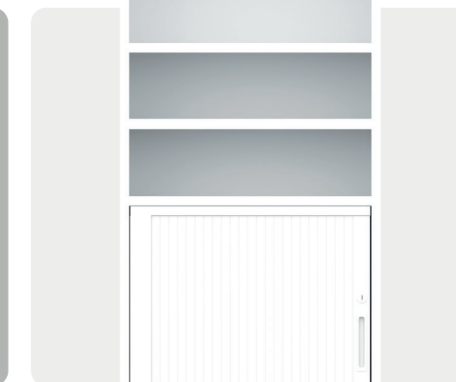
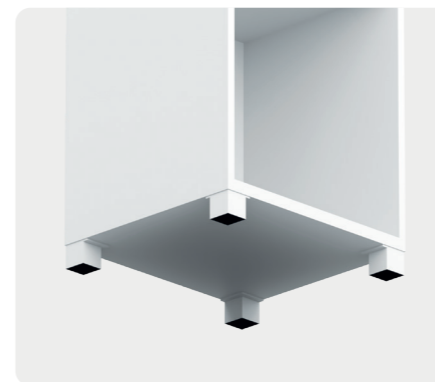

# Axis Tower Bookcase

## Product Details

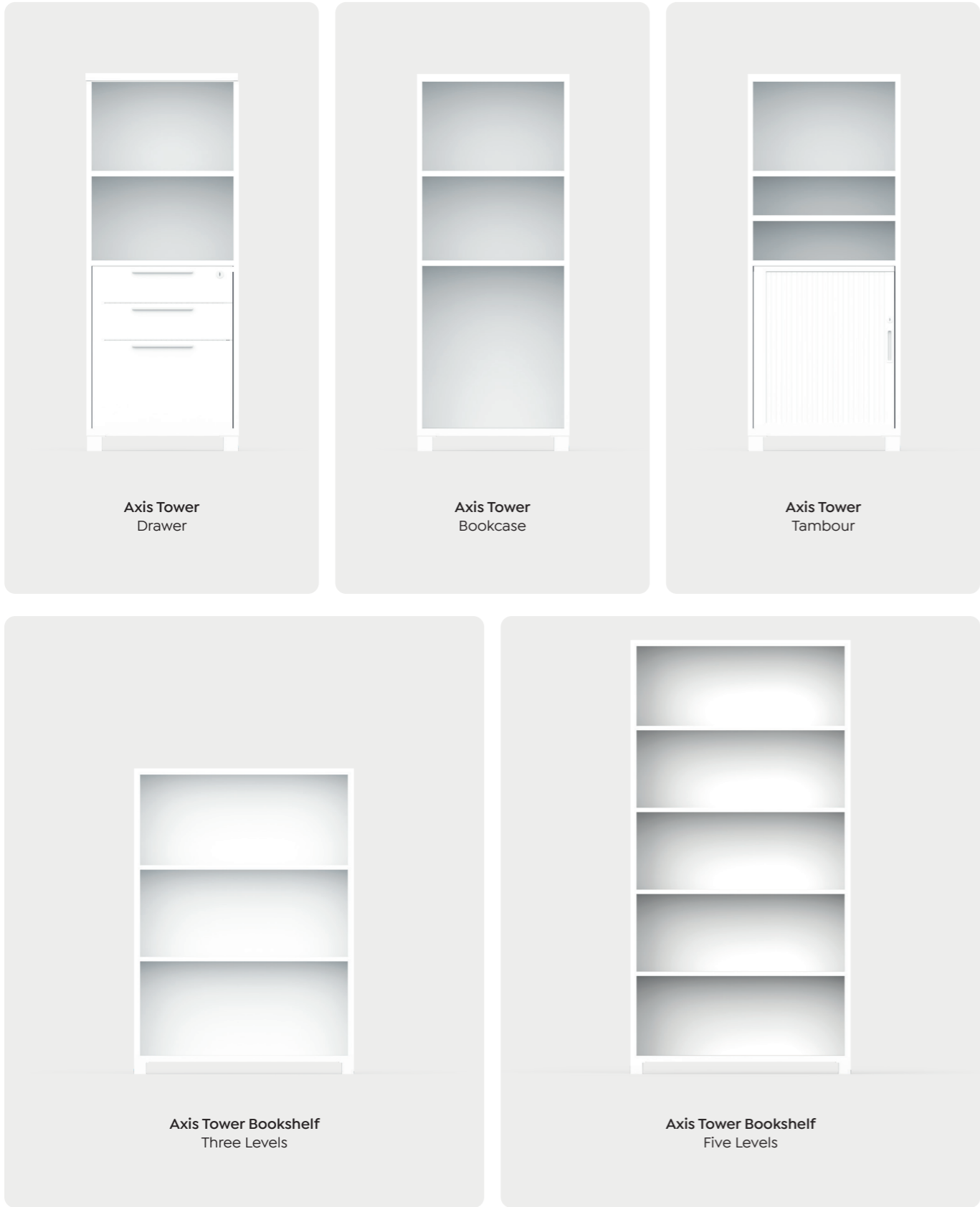



# Axis

## Filing Cabinets



### Organised Efficiency

The Axis 4 Drawer Filing Cabinet is built for high-volume, long-term performance, offering a durable and contemporary storage solution for any workspace. Constructed with 25 mm tops and bases, and 18 mm sides and shelves in white melamine on an E0-grade substrate with matching PVC edging, it delivers strength with a clean, modern finish.

A flush-joined design, supported by white powder-coated steel feet with levelling glides, enhances both stability and visual appeal. All four drawers are fitted with gang locks for secure document storage, while an integrated anti-tilt system ensures safe, reliable operation.

Dependable, stylish, and carefully engineered, the Axis 4 Drawer Filing Cabinet keeps your workspace organised and protected.

GECA Certification Available by request.

# Axis Tower Filing Cabinets

Product Details



### Features

#### Construction Materials:

25mm tops and base, 18mm sides and shelves studio white melamine on E1-grade substrate with matching PVC edge. White powdercoat 50x50mm steel feet.

#### Functional Design:

Compact and adaptable practical storage, supporting dynamic, flexible working environments.

#### Compatibility:

A perfect pairing to the Klass, Agile, Anvil and Axis desk ranges.

### Dimensions

Width	481 mm
Depth	500 mm
Height	1250 mm
Filing Drawer Height	285 mm

### Colours On-Hand

#### Stocked & Styled



White





GECA Certification Available by request.

# Axis Caddy Mobile Bookcase

Product Details

# Axis Caddy Mobile Bookcase



## Features

### Stability:

Well placed castors that enable easy manoeuvrability without compromising on function or safety.

### Compatibility:

A perfect pairing to the Klass, Agile, Anvil and Axis desk ranges.

### Finish & Inclusions:

18mm flush-joined construction. Studio White melamine on E1-grade substrate with matching PVC edge.

## Dimensions

	Mobile Bookcase	Tambour Insert	Drawer Insert
Width	994 mm	994 mm	994 mm
Depth	460 mm	460 mm	460 mm
Height	640mm	640mm	640mm

## Colours On-Hand

Stocked & Styled



White

## Organised Efficiency

The Axis caddy mobile bookcase is compatible with all Blue Ink Group desking and is a great addition for personal storage space to any workstation. Available in a number of configurations, the shelves are height adjustable for even more flexibility and customisation within the unit.

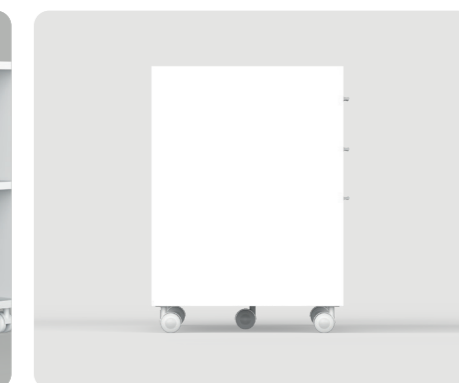
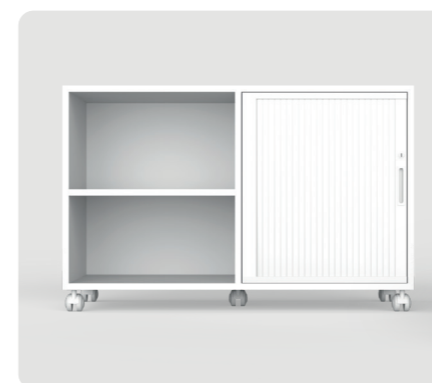

# Axis Caddy Mobile Bookcase

Product Details

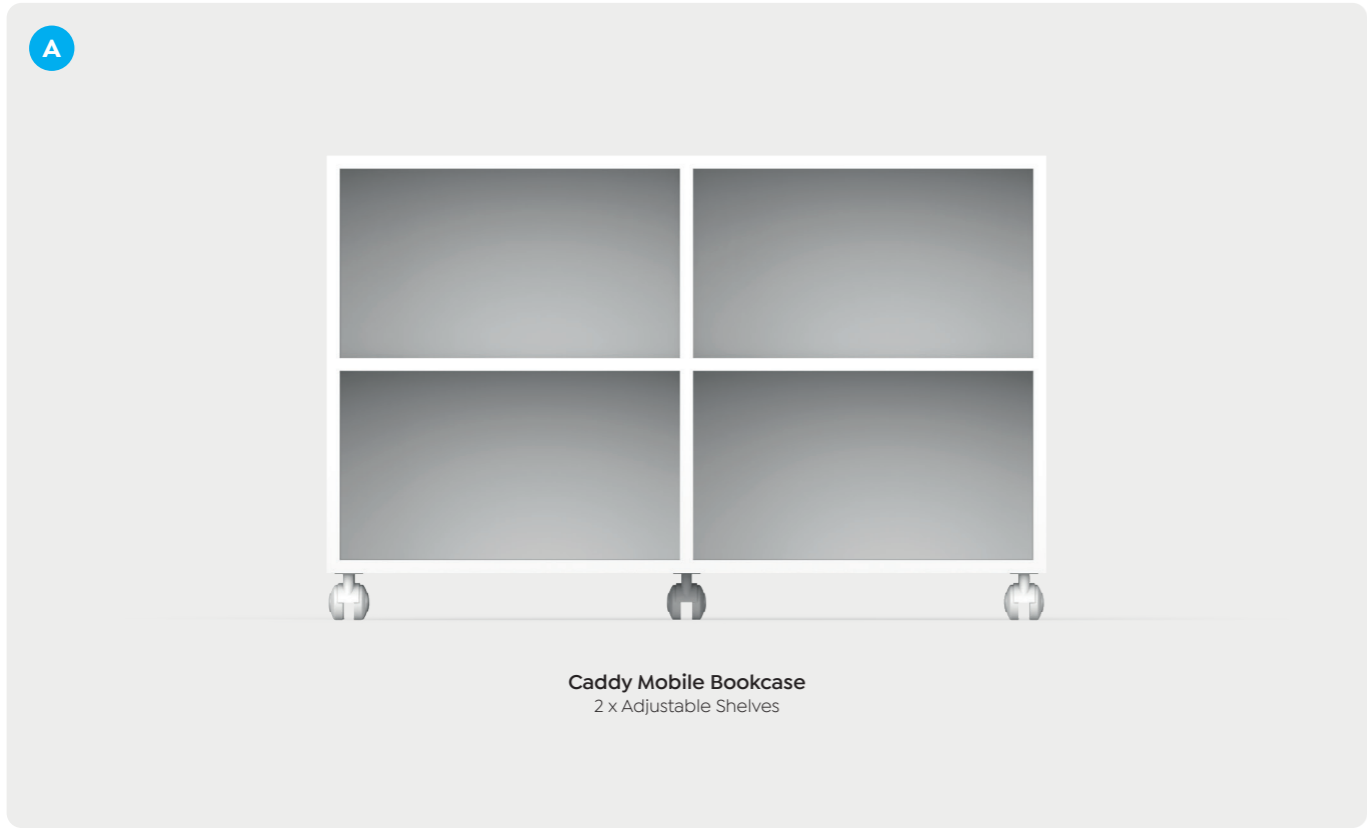

# Axis Caddy Mobile Bookcase

Product Details

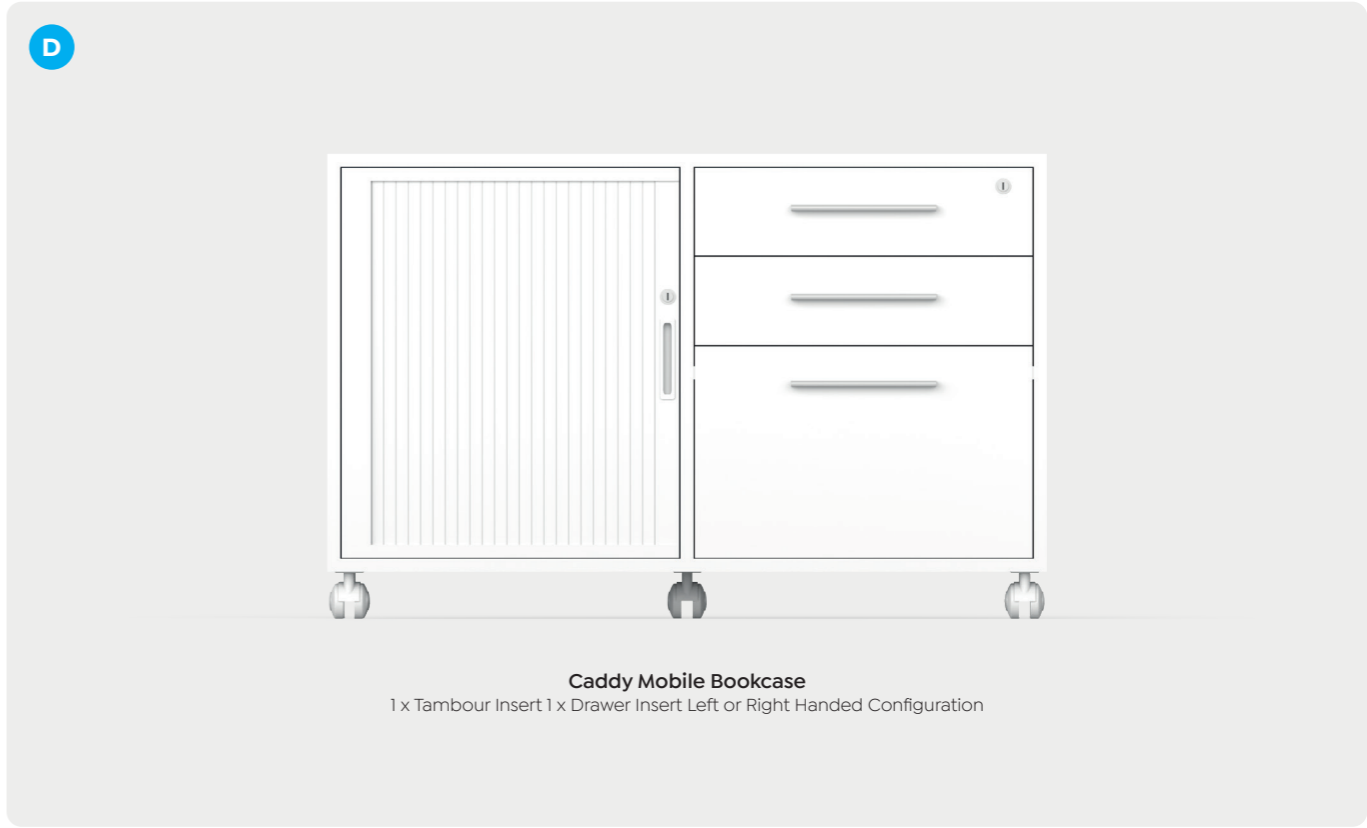



# EkoSystem Cupboard



## Simple Design Universal Appeal.

Ekosystem is a collection of workspace furniture, inspired by the needs of small to medium businesses, and built with top quality materials and experienced workmanship. A 10 year warranty across the range backs up the robust, durable design, with features such as E1-grade 25mm melamine tops and frame panels and BIFMA tested fittings.

Designed for fast assembly, it is available in three-level or five-level options. Choose between all white or charcoal/new oak finishes to complement any office decor.

# EkoSystem Cupboard

GECA Certification Available by request.

Product Details



EkoSystem Cupboard  
1200 mm



EkoSystem Cupboard  
1800 mm

## Features

### Construction Materials:

The Ekosystem Cupboard features 25 mm tops and base, with 18 mm sides and shelves in white or new oak/charcoal melamine on.

### Compatibility:

A perfect pairing to the Klass, Agile, Anvil and Axis desk ranges.

### Finish & Inclusions:

E1-grade substrate with matching PVC edges. It includes soft close hinges and adjustable shelves for enhanced functionality

## Dimensions

	1200 Cupboard	1800 Cupboard
Width	800 mm	800 mm
Depth	400 mm	400 mm
Height	1200 mm	1800 mm

## Colours On-Hand

Stocked & Styled





# EkoSystem Bookcase



## Simple Design Universal Appeal.

Crafted for durability and everyday performance, the EkoSystem Bookcase is built from 18 mm studio white or new oak/charcoal melamine on an E1-grade substrate, finished with matching PVC edging for a refined, seamless look. Adjustable shelves and a sturdy 5 mm MDF back panel offer practical flexibility for a variety of storage needs.

Designed for fast, effortless assembly, the range is available in three-level or five-level configurations and in three versatile sizes. Choose from studio white or charcoal/new oak finishes to complement any workspace or home environment.

The EkoSystem Bookcase delivers functional, stylish storage, built to work wherever you do.

GECA Certification Available by request.

# EkoSystem Bookcase

Product Details

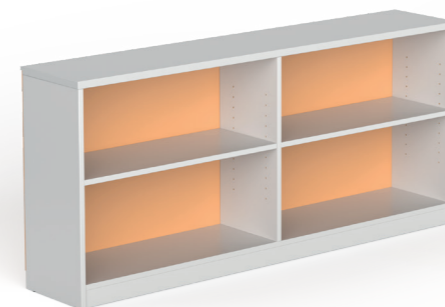

EkoSystem Bookcase  
Wide



EkoSystem Cupboard  
3-Level



EkoSystem Cupboard  
5-Level

## Features

### Construction Materials:

18 mm studio white or new oak/charcoal melamine on E1-grade substrate with matching PVC edge, 5mm MDF backing board

### Functional Design:

Adjustable shelves and fast assembly  
3 level option or 5 level option available  
3 sizes available

### Compatibility:

A perfect pairing to the Klass, Agile, Anvil and Axis desk ranges.

## Dimensions

	Wide	3-Level	5-Level
Width	1600 mm	800 mm	800 mm
Depth	300 mm	300 mm	300 mm
Height	720 mm	1200 mm	1800 mm

## Colours On-Hand

Stocked & Styled

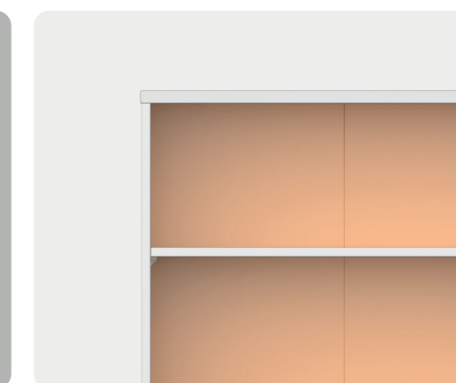
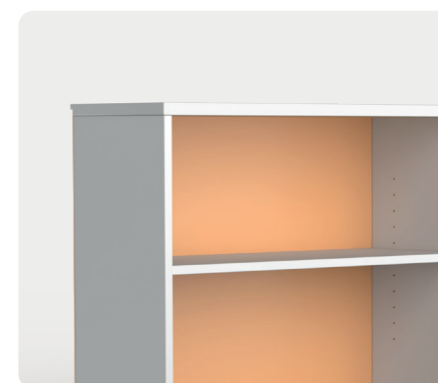
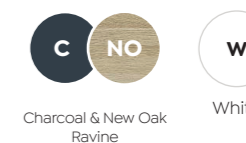



# EkoSystem Mobile Bookcase



## Simple Design Universal Appeal.

Compact and adaptable, the Ekosystem Mobile Bookcase Unit offers practical storage in a streamlined W440 x D500 x H600 footprint. Finished in charcoal or white melamine on an E1-grade substrate with matching PVC edging, it delivers durability with a refined, modern look.

An adjustable shelf provides flexible organisation, and the unit is designed to integrate effortlessly with an optional drawer for enhanced functionality. Its mobile construction allows it to move easily within any workspace, supporting dynamic, flexible working environments.

A sleek and reliable storage solution, the Ekosystem Mobile Bookcase Unit is built to keep your space organised and working smoothly.

GECA Certification Available by request.

# EkoSystem Mobile Bookcase

Product Details



EkoSystem Mobile Bookcase



EkoSystem Mobile Caddy Unit



EkoSystem Drawer Unit Non-Locking



EkoSystem Drawer Unit Non-Locking

## Features

### Construction Materials:

18 mm studio white or new oak/charcoal melamine on E1-grade substrate with matching PVC edge, 5mm MDF backing board.

### Functional Design:

Compact and adaptable practical storage, it moves easily within any workspace, supporting dynamic, flexible working environments.

### Compatibility:

A perfect pairing to the Class, Agile, Anvil and Axis desk ranges.

## Dimensions

Variants	Bookcase	Caddy Unit
Width	440 mm	858 mm
Depth	500 mm	500 mm
Height	600 mm	600 mm

## Colours On-Hand

Stocked & Styled

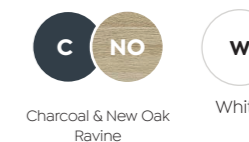



# EkoSystem Desktop Shelf

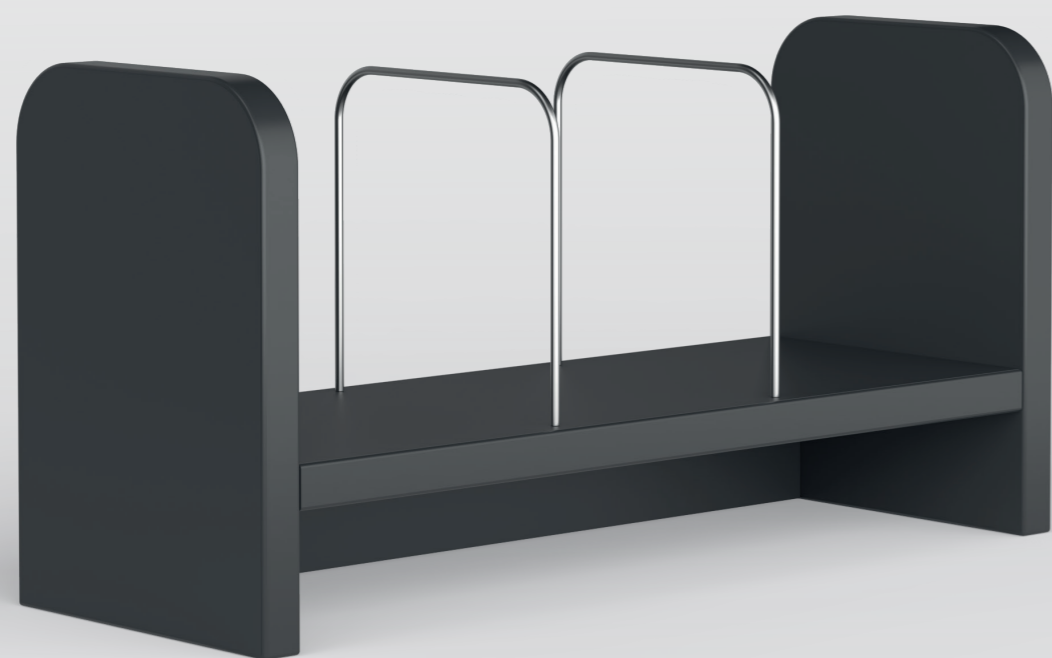

## Simple Design Universal Appeal.

The EkoSystem Desktop Shelf brings practical organisation to your workspace, featuring two chrome bookend hoops that keep books and documents neatly in place. At 600mm wide, it aligns seamlessly with the complete EkoSystem range for a cohesive, coordinated look.

Crafted from 18 mm melamine on an E1-grade substrate with matching PVC edging, it is available in charcoal or white finishes to suit any setting. Designed for simplicity and everyday function, this desktop shelf offers a stylish, space-efficient way to keep your work essentials within easy reach.

GECA Certification Available by request.

# EkoSystem Desktop Shelf

Product Details



## Features

### Construction Materials:

18 mm studio white or new oak/charcoal melamine on E1-grade substrate with matching PVC edge.

### Versatile Storage:

Designed for simplicity and everyday function, this desktop shelf offers a stylish, space-efficient way to keep your work essentials within easy reach.

### Compatibility:

Aligns seamlessly with the complete EkoSystem range for a cohesive, coordinated look.

## Dimensions

Width	600 mm
Depth	215 mm
Height	300 mm

## Colours On-Hand

### Stocked & Styled

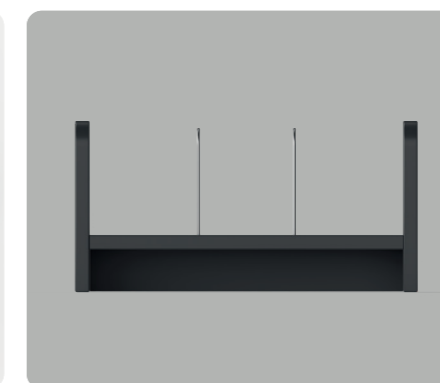
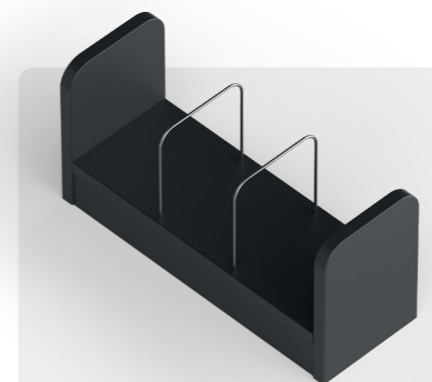
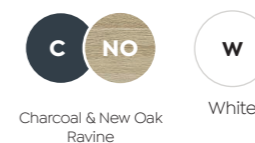



# EkoSystem Hutch

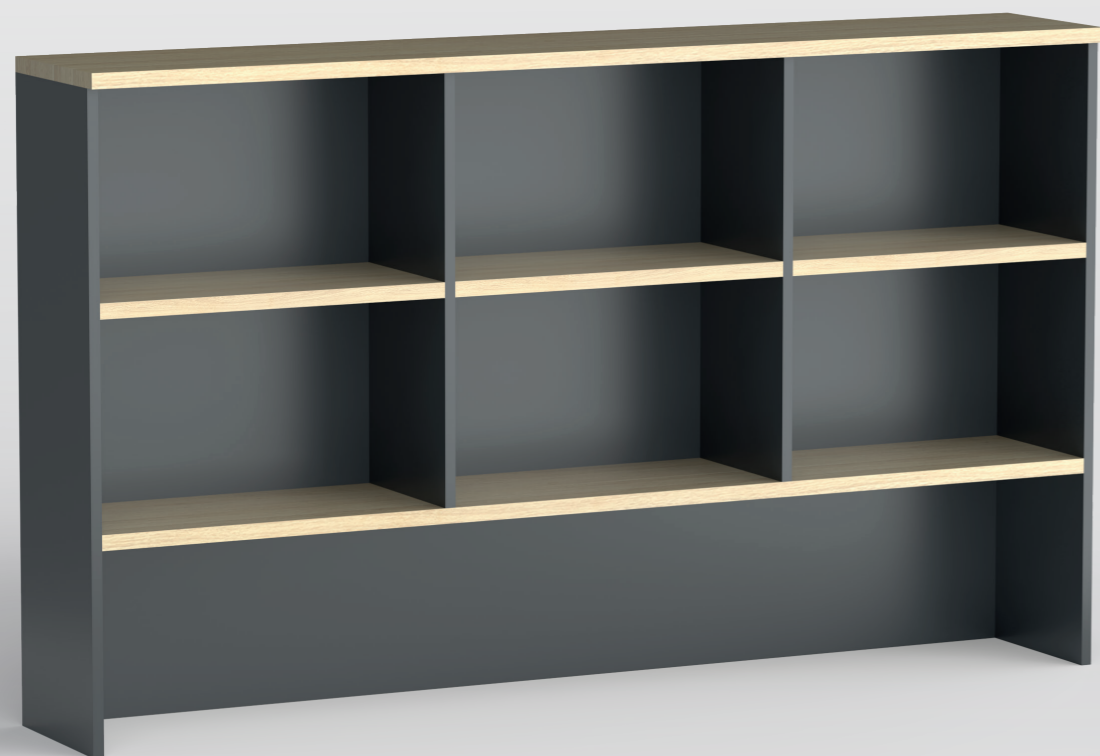

## Simple Design Universal Appeal.

The EkoSystem Hutch Unit delivers adaptable, streamlined storage, available in three widths, 1200mm, 1500mm, and 1800mm, to suit a variety of workspaces. Finished in charcoal/new oak or all white, it is crafted from 18 mm melamine on an E1-grade substrate with matching PVC edging for a refined, durable construction.

Designed to integrate effortlessly with the full EkoSystem range, this hutch enhances any office or home workspace with its clean lines and practical functionality. Offering both style and efficiency, it provides an elevated storage solution that supports an organised and cohesive environment.

GECA Certification Available by request.

# EkoSystem Hutch

Product Details



## Features

### Construction Materials:

18 mm studio white or new oak/charcoal melamine on E1-grade substrate with matching PVC edge, 5mm MDF backing board.

### Style and Functionality:

Offering both style and efficiency, it provides an elevated storage solution that supports an organised and cohesive environment.

### Effortless Integration:

Designed to integrate effortlessly with the full EkoSystem range, this hutch enhances any office or home workspace with its clean lines and practical functionality.

### Options and Finishes:

Colour finish: Charcoal/New Oak or All White  
Material description: Melamine.

## Colours On-Hand

### Stocked & Styled

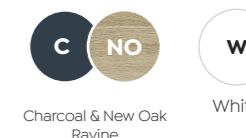

Charcoal & New Oak Ravine

White

## Dimensions

Variants	1200 Hutch	1500 Hutch	1800 Hutch
Width	1200 mm	1500 mm	1800 mm
Depth	315 mm	315 mm	315 mm
Height	1070 mm	1070 mm	1070 mm

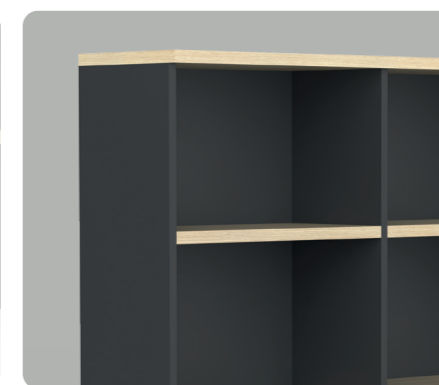
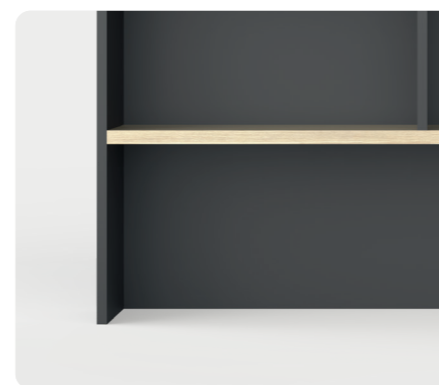

# EkoSystem Hutch

Product Details

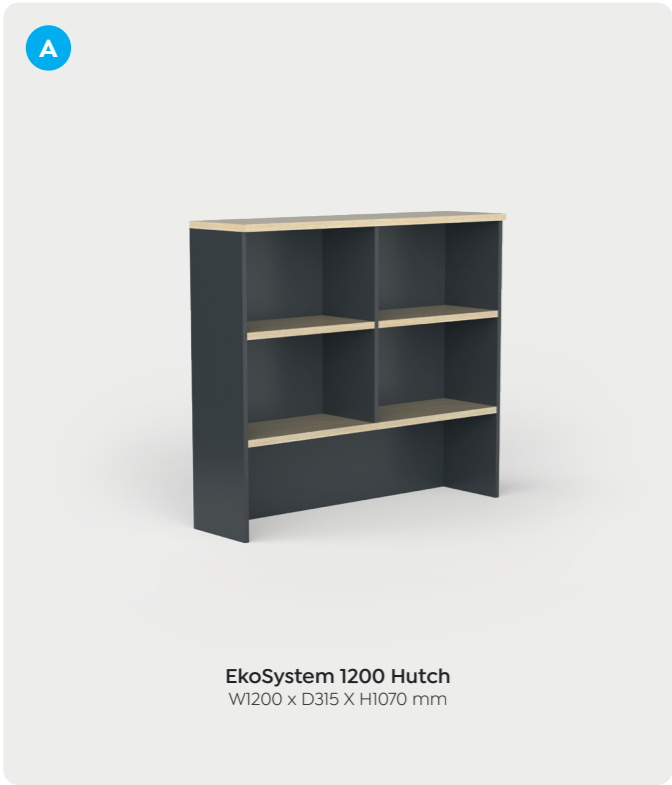

# EkoSystem Hutch

Product Details





# Rover<sup>®</sup> Range Bookcase



## Refine, Reconfigure, Rover.

A fusion of aspirational design and functionality designed to transform your workspace into a dynamic, adaptable environment.

Each piece is meticulously crafted with large medical-grade castors, acoustic elements, enabling a quieter, more focused environment and timber accents from FSC-certified sources adds a touch of natural elegance, making each piece both functional and stylish.

Timber sourced from a FSC Certified Forest

# Rover<sup>®</sup> Range Bookcase

Product Details



Mobile Bookcase Small



Mobile Bookcase

## Features

**FSC-Certified Timber Frame:**  
Real timber accents from FSC-certified sources add a touch of nature to any space.



**Acoustic & Pinnable Recycled Board:**  
Enhance your workplace acoustics with our recycled acoustic board panels with a high Noise Reduction Coefficient (NRC) rating of 0.35

**Large Medical Grade Castors:**  
Experience effortless mobility with large medical-grade castors, designed for smooth, reliable movement and easy reconfiguration of spaces.

## Dimensions

Variants	Small Bookcase	Bookcase
Width	900 mm	900 mm
Depth	315 mm	315 mm
Height	1620 mm	1920 mm

## Colours On-Hand

Stocked & Styled



White & Maple Hardwood



White & Grey Castors

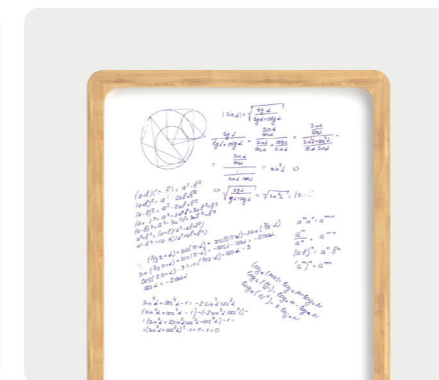



# Rover<sup>®</sup> Range Cupboards



## Refine, Reconfigure, Rover.

A fusion of aspirational design and functionality designed to transform your workspace into a dynamic, adaptable environment.

Each piece is meticulously crafted with large medical-grade castors, acoustic elements, enabling a quieter, more focused environment and timber accents from FSC-certified sources adds a touch of natural elegance, making each piece both functional and stylish.

Timber sourced from a FSC Certified Forest

# Rover<sup>®</sup> Range Cupboards

Product Details



Mobile Cupboard



Mobile Cupboard + Planter

## Features

**FSC-Certified Timber Frame:**  
Real timber accents from FSC-certified sources add a touch of nature to any space.



**Acoustic & Pinnable Recycled Board:**  
Enhance your workplace acoustics with our recycled acoustic board panels with a high Noise Reduction Coefficient (NRC) rating of 0.35

**Large Medical Grade Castors:**  
Experience effortless mobility with our large medical-grade castors, designed for smooth, reliable movement and easy reconfiguration of spaces.

**Soft-close Hinges:**  
Enjoy a quieter, more refined user experience with soft-close hinges that prevent slamming and ensure smooth operation.

**Aluminium Handles:**  
Benefit from the sleek durability of Aluminium handles, combining modern aesthetics with long-lasting performance.

**Adjustable Shelving:**  
Optimise your storage space with adjustable shelving, allowing for flexible organisation tailored to your needs.

## Dimensions

Variants	Mobile Cupboard	Mobile Cupboard + Planter
Width	900 mm	900 mm
Depth	315 mm	315 mm
Height	1320 mm	1620 mm

## Colours On-Hand

Stocked & Styled

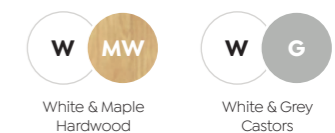

# Lockers

Secure practical storage solutions.

Designed for modern workplaces and learning environments, this locker range offers a secure and intuitive storage solution for shared spaces and multiple users. Constructed with durability and visual consistency in mind, with multiple door combinations to suit varied user needs, supporting everyday practicality.

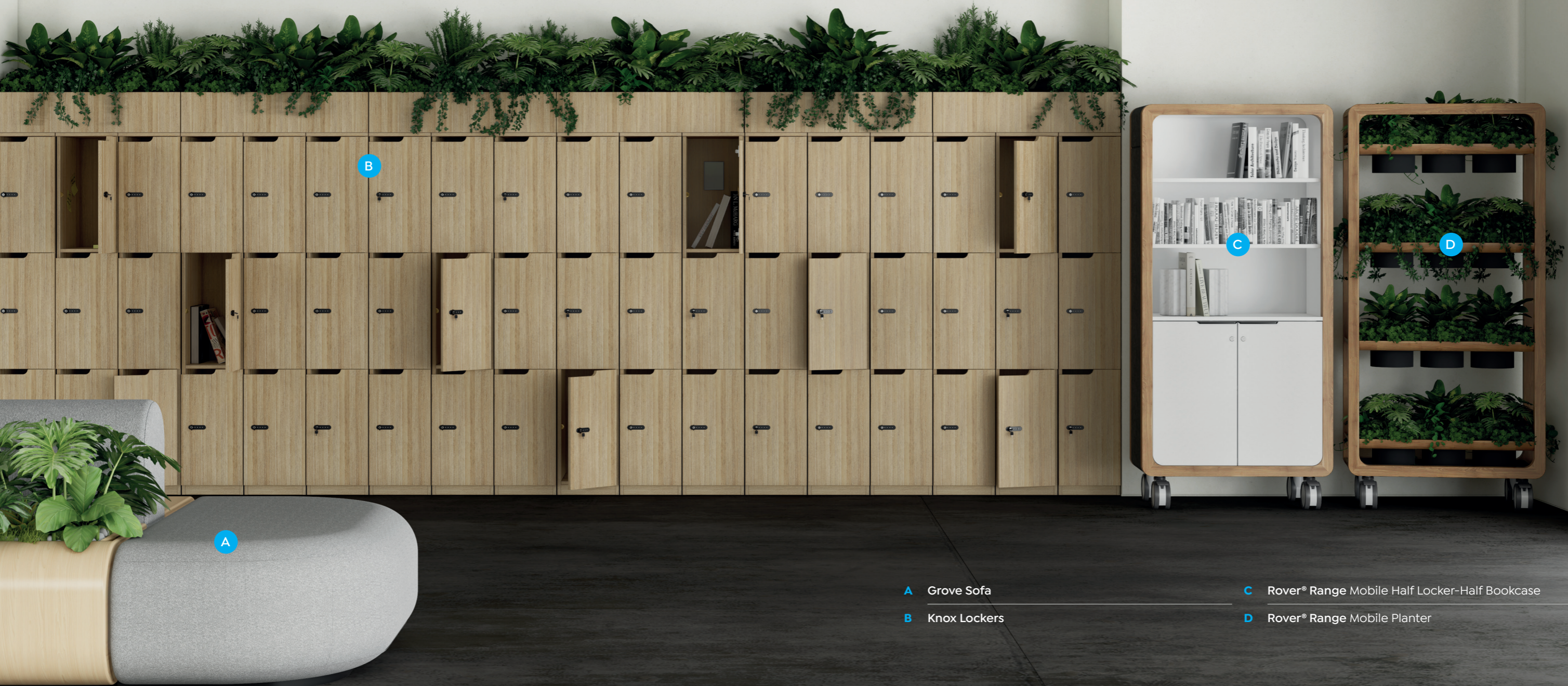

A

B

C

D

A Grove Sofa

B Knox Lockers

C Rover® Range Mobile Half Locker-Half Bookcase

D Rover® Range Mobile Planter



# Axis Locker



## Organised efficiency.

The Axis locker is a secured storage locker solution for multiple-user needs. To keep each user's belongings private and safe, each locker compartment has a factory-installed lock and a set of 2 keys. The locker has both three-door and double 6-door options available.

The locker has 18 mm White melamine on an E0-grade substrate with a matching PVC edge. It also has flush-joined construction and includes white powder-coated steel feet with glides for levelling adjustment.

GECA Certification Available by request.

# Axis Locker

Product Details



**Axis Locker Single Three Door**  
W380 x D450 x H1800 mm



**Axis Locker Double Six Door**  
W738 x D450 x H1800 mm

## Features

### Stylish Design:

Flush-joined construction, individual locking on all doors. Each locker compartment has a factory-installed lock and a set of 2 keys.

### Compatibility:

A perfect pairing to the Axis desk and storage range.

### Finish & Inclusions:

Two height options of 3 locker or 6 locker. White, Melamine E1-grade substrate with matching PVC edge.

## Colours On-Hand

### Stocked & Styled

CW

Classic White

## Dimensions

Variants	Single Three Door	Double Six Door
Width	380 mm	738 mm
Depth	450 mm	450 mm
Height	1800 mm	1800 mm





# Knox Locker



## Secure and Effortless Storage for Modern Spaces.

The Knox Lockers Range, a smart and secure solution designed for modern office and educational spaces.

Knox lockers offer keyless entry with combination locks and master key override, ensuring hassle-free access and security. With unique mail slots that enhance air ventilation and easy-to-open doors, the Knox lockers are both a practical and user-friendly storage solution for any space.

GECA Certification Available by request.

# Knox Locker

Product Details



## Features

### Secure Access Options:

Provides both key and keyless entry through a combination lock, with a master key override for authorised access when needed.

### Enhanced Mail Slot Design:

Smooth-finished mail slots ensure easy access while also improving ventilation within the locker.

### Flexible Storage Configuration:

Equipped with hanging rail facilities suitable for both 1-door and 2-door lockers to support various storage needs.

### Integrated Planter Box System:

Planter boxes include waterproof drip trays for easy maintenance and added functionality.

### Easy Installation & Stability:

Designed for quick installation and fitted with adjustable levelling feet to ensure stability on uneven surfaces.

### Durable Construction & Warranty:

Built with a solid 18mm melamine back panel for secure wall fixing and backed by a 10-year warranty for long-term reliability.

## Colours On-Hand

### Stocked & Styled



New Oak Ravine



Nordic Maple

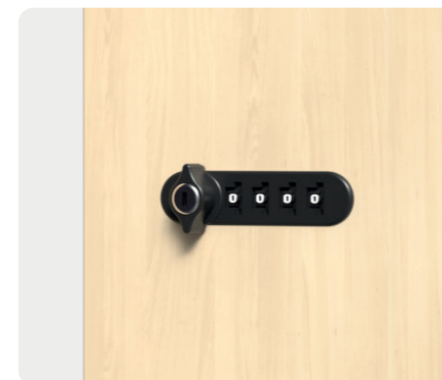

# Knox Locker

Product Details

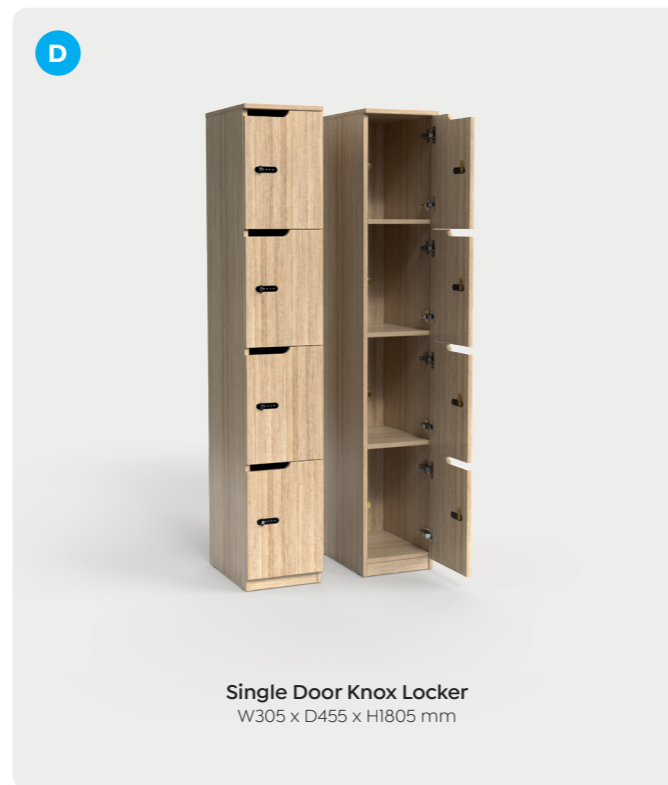
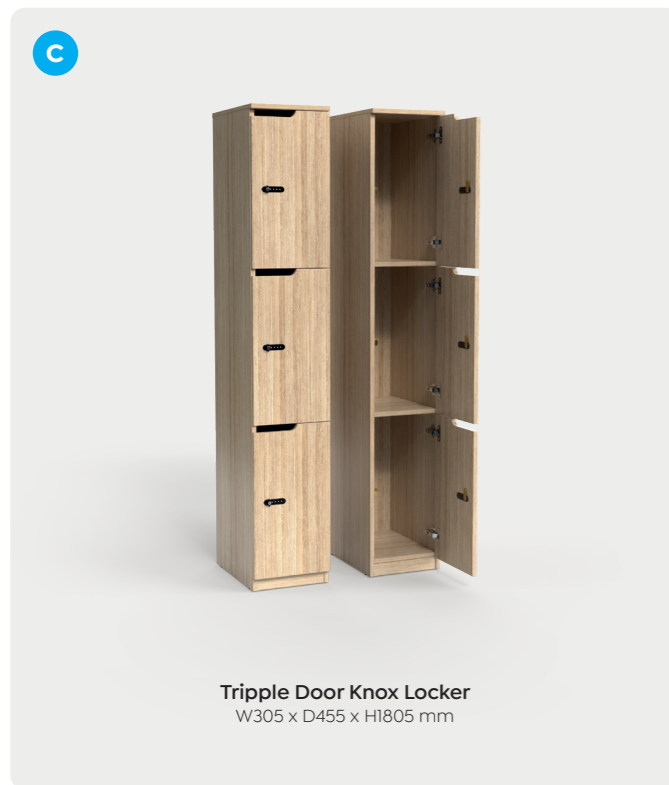
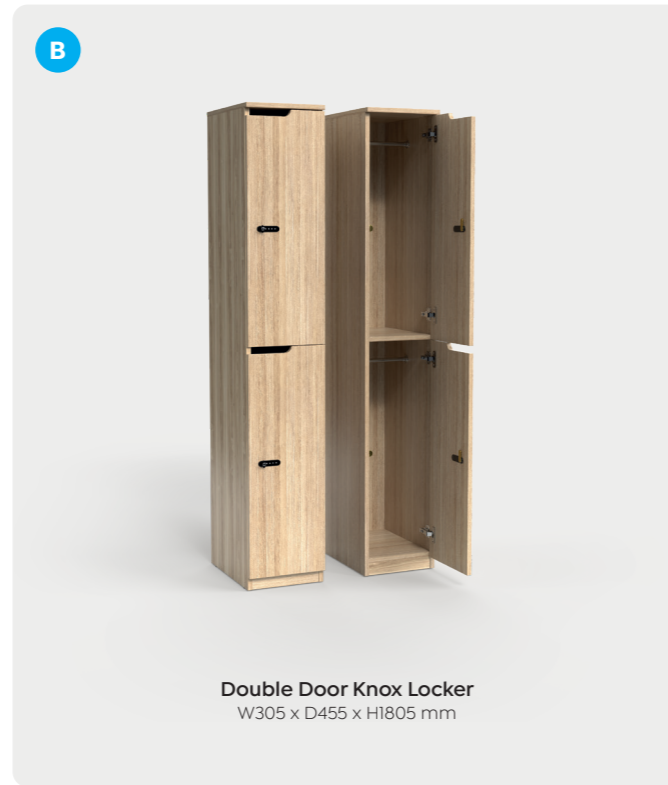
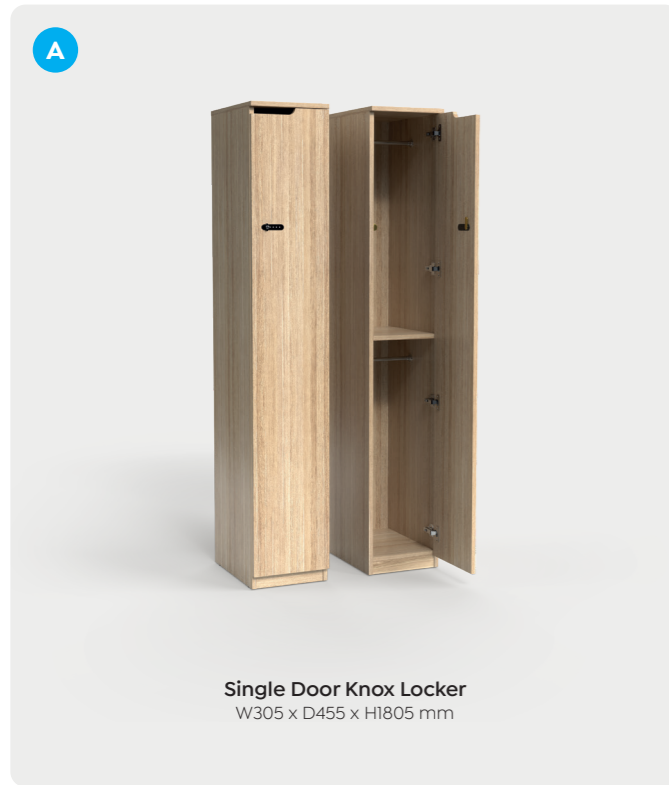

# Knox Locker

Product Details

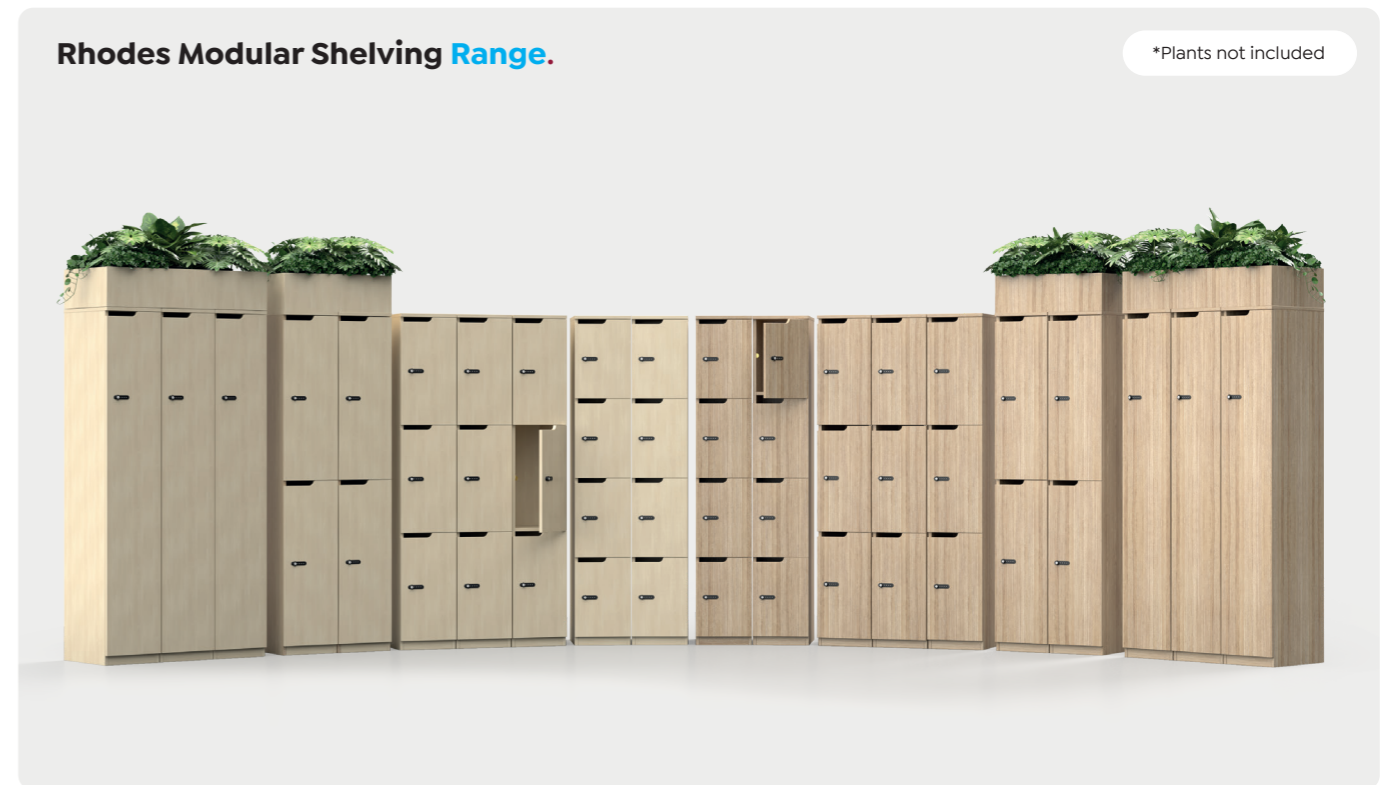
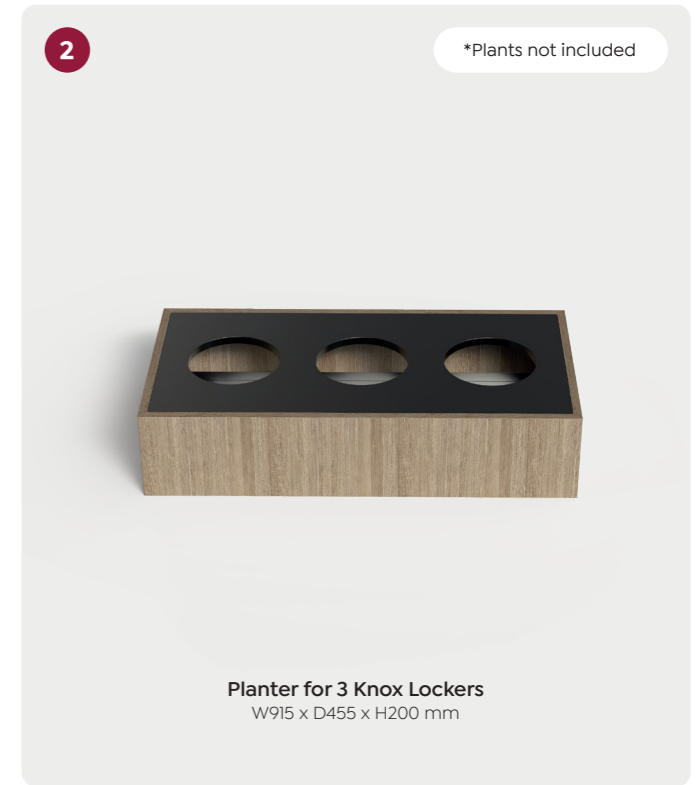
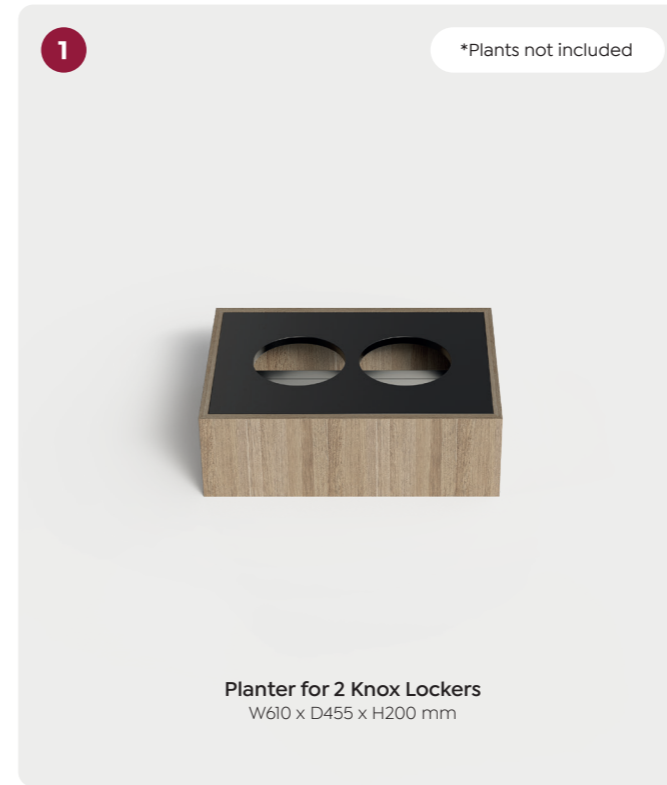



# Rover® Range Locker



## Refine, Reconfigure, Rover.

A fusion of aspirational design and functionality designed to transform your workspace into a dynamic, adaptable environment.

Each piece is meticulously crafted with large medical-grade castors, acoustic elements, enabling a quieter, more focused environment and timber accents from FSC-certified sources adds a touch of natural elegance, making each piece both functional and stylish.

Timber sourced from a FSC Certified Forest

# Rover® Range Locker

Product Details



Mobile Locker



Mobile Locker + Planter



Mobile Half Locker / Bookcase

## Features

**FSC-Certified Timber Frame:** Real timber accents from FSC-certified sources add a touch of nature to any space.



**Acoustic & Pinnable Recycled Board:** Enhance your workplace acoustics with our recycled acoustic board panels with a high Noise Reduction Coefficient (NRC) rating of 0.35

**Large Medical Grade Castors:** Experience effortless mobility with large medical-grade castors, designed for smooth, reliable movement and easy reconfiguration of spaces.

**Soft-close Hinges:** Enjoy a quieter, more refined user experience with soft-close hinges that prevent slamming and ensure smooth operation.

**Aluminium Handles:** Benefit from the sleek durability of Aluminium handles, combining modern aesthetics with long-lasting performance.

**Adjustable Shelving:** Optimise your storage space with adjustable shelving, allowing for flexible organisation tailored to your needs.

## Dimensions

Variants	Locker	Locker + Planter	Half Locker / Bookcase
Width	900 mm	900 mm	900 mm
Depth	315 mm	315 mm	315 mm
Height	1620 mm	1920 mm	1920 mm

## Colours On-Hand

Stocked & Styled

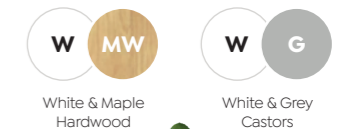



# Reception

Design that greets you.

Blue Ink Group's Reception solutions set the tone with clean geometry, carefully resolved detailing and robust construction. Designed to complement the broader Blue Ink Group furniture palette, each piece balances form and function.

A Grove Sofa

B Sora Orbit Coffee Table

C Tempo Sliding Door Credenza

D Anvil Reception

E AcoustIQ Unique Printed Panels



# Anvil Reception



## Seamless Function and Style.

Where style meets functionality the Anvil reception counter provides a professional first impression. With its sophisticated design and robust construction and crafted with 18 mm white melamine on an E1-grade substrate, complete with a matching PVC edge for a clean and durable finish.

The flush-joined construction detailing ensures a sleek and seamless look. Featuring a silver centre panel, perfect for showcasing branding or signage within your space. All reception options require free-standing work surfaces, allowing for a customisable setup that meets the specific needs of your space.

GECA Certification Available by request.

# Anvil Reception

Product Details

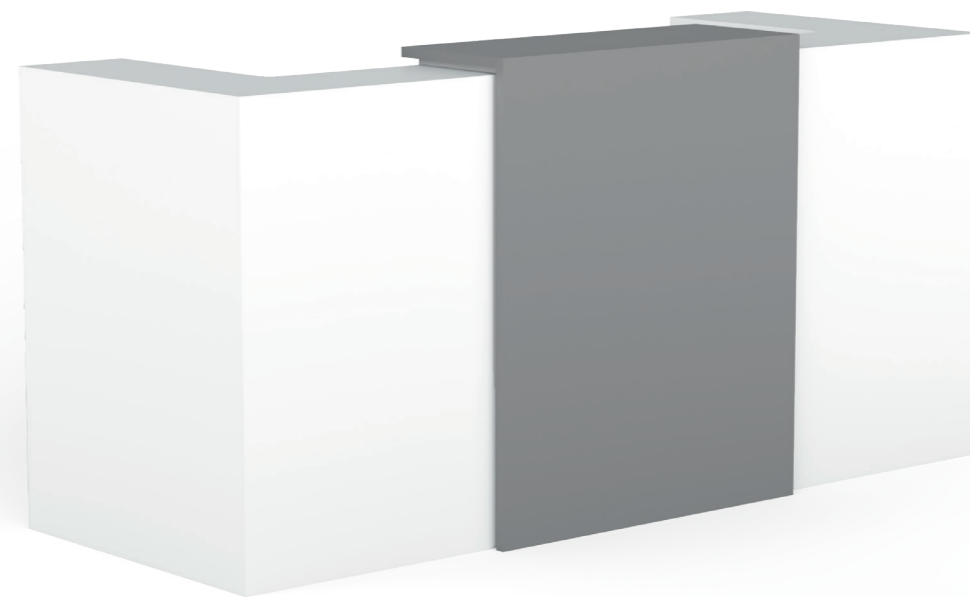

## Features

### Stylish Design:

Durable and elegant the feature panel is perfect for showcasing branding or signage.

### Compatibility:

A perfect pairing to the Klass, Agile, Anvil and Axis desk ranges.

### Options & Finishes:

White/Silver, Melamine, E1-grade substrate with matching PVC edge.

### Options & Finishes:

White/Silver, Melamine, E1-grade substrate with matching PVC edge.

### Versatility:

The concealed telescopic chassis adjusts to fit worktop sizes from 180mm to 2400mm.

## Dimensions

Minimum closed, external		Maximum open, external	
Width (Fits 1800mm width desk)	1846 mm	Width (Fits 1240mm width desk)	2446 mm
Thickness	934 mm	Thickness	934 mm
Height	1200 mm	Height	1200 mm

## Colours On-Hand

Stocked & Styled

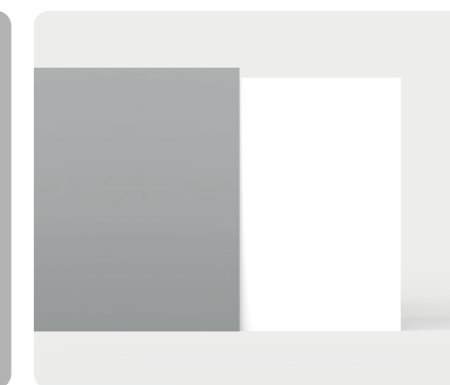
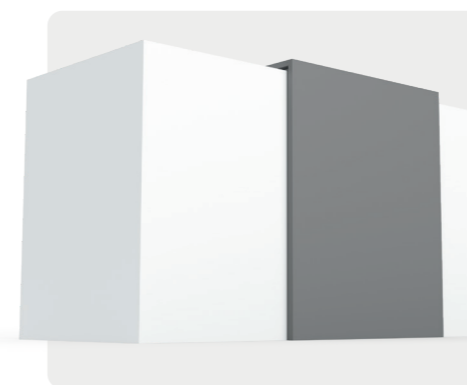
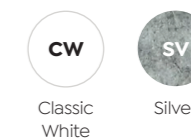



GECA Certification Available by request.

# Axis Reception

Product Details

# Axis Reception



## Simple Design, Universal Appeal

The Axis Reception Range creates a professional first impression.

A simple universal design designed to elevate any reception with its sophisticated design and robust construction. Each piece is crafted with 18 mm white melamine on an E1-grade substrate, complete with a matching PVC edge for a clean and durable finish. The flush-joined construction detailing ensures a sleek and seamless look.

With straight or 90° options available to suit various reception layouts, providing flexibility and versatility in design. Free-standing work surfaces are required, allowing for a customisable setup that meets the specific needs of your space.

## Features

### Compatibility:

A perfect pairing to the Klass, Agile, Anvil and Axis desk ranges.

### Finish & Inclusions:

White, Melamine, E1-grade substrate with matching PVC edge.

### Stylish Design:

Durability and sophistication with functional design. The flush joined construction detailing ensures a seamless appearance, while the Aluminium beading detail on the front adds a touch of elegance.

### Versatility:

Additional pop-top option. Requires a free standing work surface, designed to accommodate a 1800mm wide desk within its 1842mm width.

## Colours On-Hand

### Stocked & Styled



Classic White

See the next page for detailed dimensions ▶

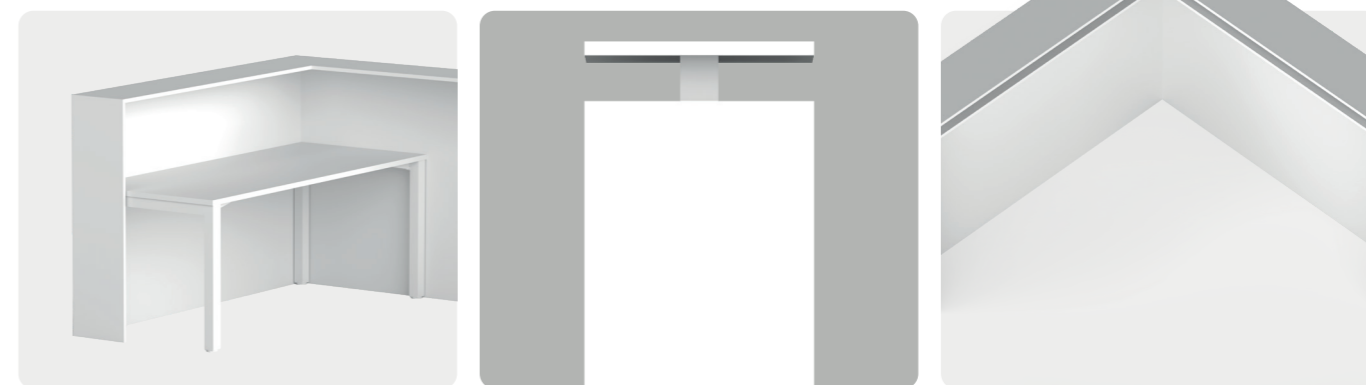

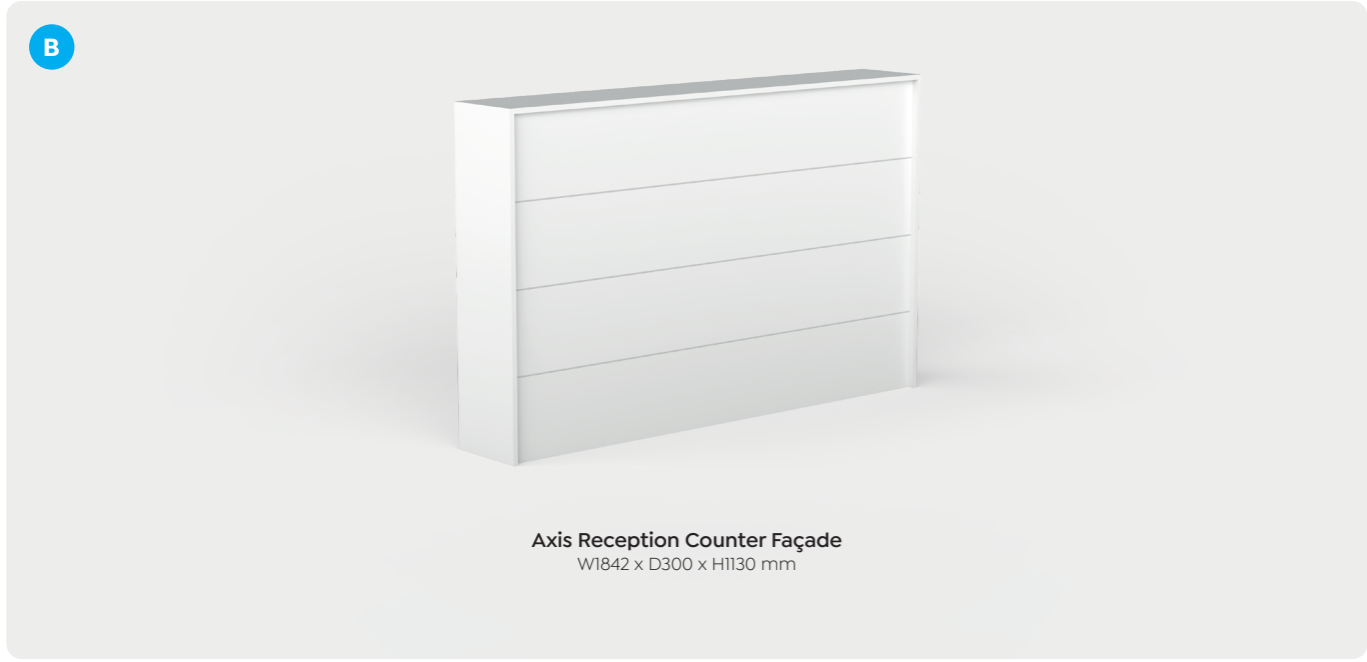

**Best paired with.**

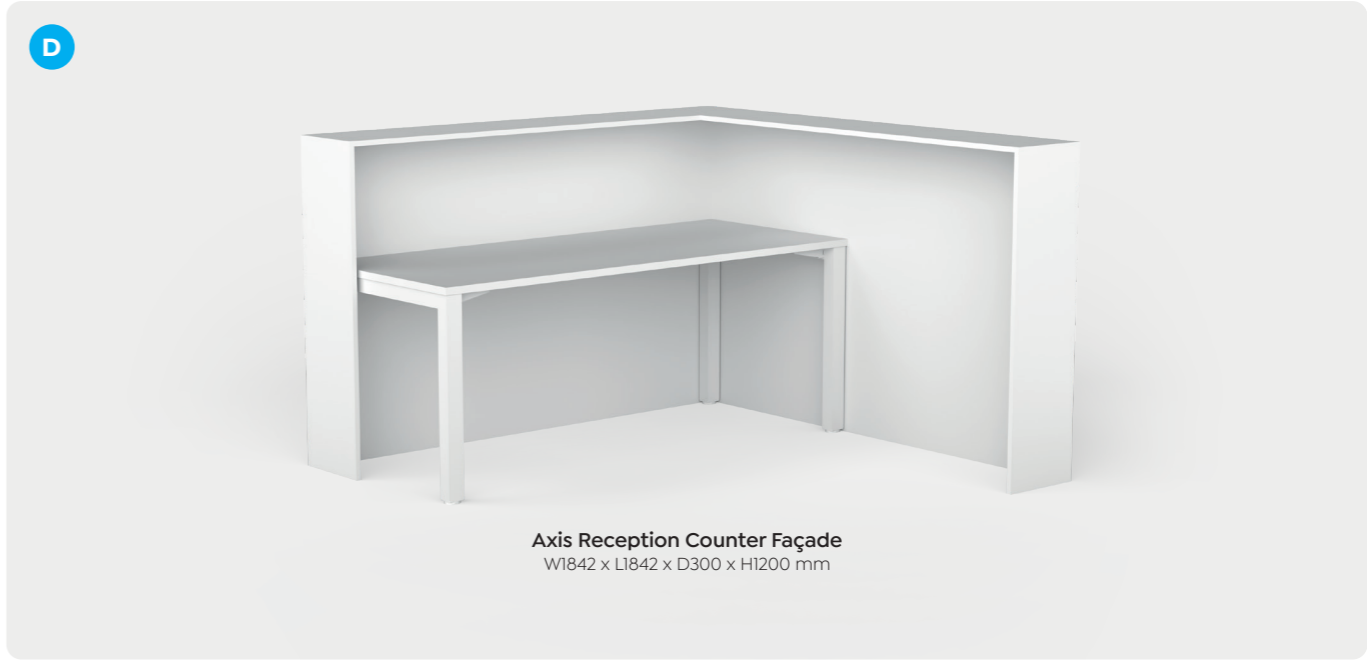
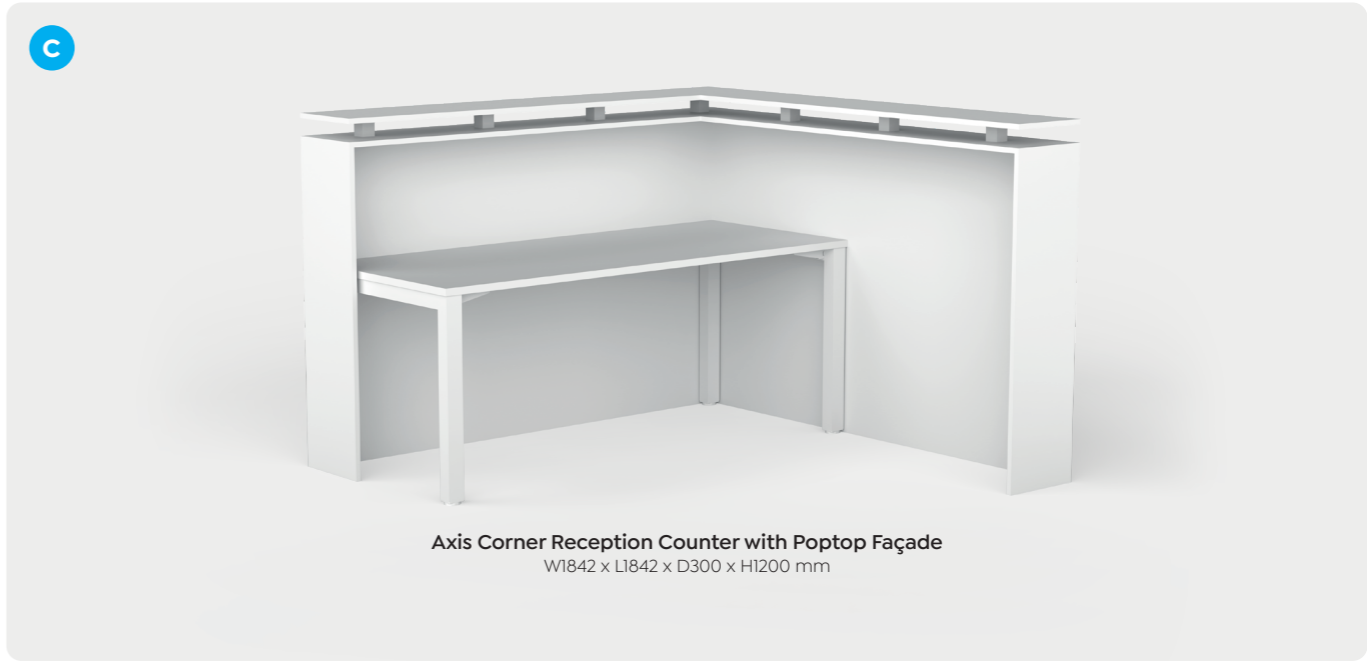
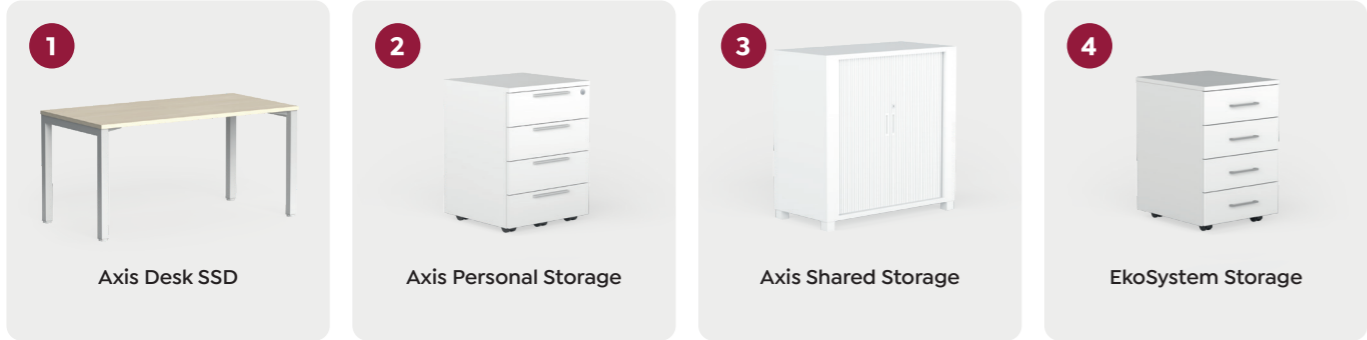

**Best paired with.**

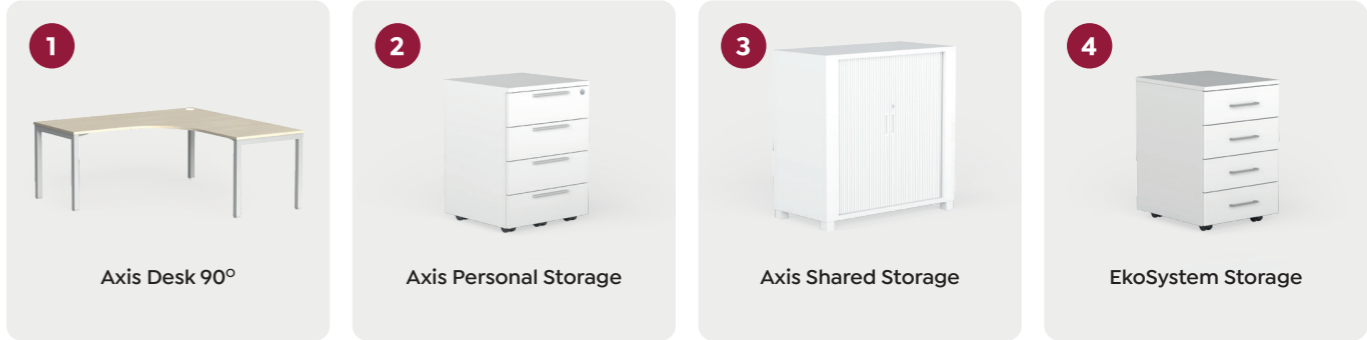



# Partner with us

At Blue Ink Group, we deliver on our commitment by working together to provide a solution-focused approach to meet your specific needs. We strive to be efficient in the value creation in our supply chain system and operations to produce aspirational and functional products delivered with exceptional standards.

- A** Rover® Range Mobile Rubbish Bin
- B** Rover® Range Mobile Credenza + Planter
- C** Motion Sync Chair
- D** Rover® Range Mobile Planter Large
- E** Mesa Wooden Base Armchair
- F** AcoustIQ Nimbus Sound Clouds
- G** Disc Base Breakout Table
- H** Rover® Range Mobile Bookcase Large

We believe in building enduring partnerships to achieve mutual outcomes.

# blueink



176-178 Gladstone Street Fyshwick ACT 2609 Australia

Canberra: (02) 6166 6000 Sydney: (02) 9308 6006

Email: [sales@blueingroup.com.au](mailto:sales@blueingroup.com.au)

[www.blueingroup.com.au](http://www.blueingroup.com.au)