

blueink



AcoustIQ

Aspirational Design Meets Functional Solutions



## The Importance of Smart Acoustics

In contemporary workspaces, acoustics directly impact productivity, comfort, and overall well-being. Excessive noise and poor acoustic management disrupt concentration, increase stress, and significantly reduce efficiency.

Blue Ink Group uniquely integrates high-quality commercial furniture solutions with advanced acoustic technologies. At Blue Ink Group, acoustics are more than noise control, they represent intelligent design, seamlessly combining aesthetics, performance, and innovation to enhance workspace harmony and productivity.

A	Sonus	6
B	V-Line	10
C	Contour	14
D	Breeze	18
E	Nimbus	22
F	Ceiling Tiles	26
G	Zen Screens	30
	Zen Screens	32
	Zen Curved Screens	38
	Zen Edge25 Screens	40
H	Mosaic	44
I	Unique Printed Panels	46
	Colour Options	50

## Technical Specifications

AcoustIQ panels feature meticulous engineering and rigorous testing to deliver exceptional acoustic performance:



**Noise Reduction Coefficient (NRC)**  
Acoustic performance 0.35 - 0.90.



**Fire Safety Compliance**  
Group 1 Classification under AS ISO 9705 and AS 5637.1 (Australian Fire Standards).



**Material Composition**  
100% PET, minimum 60% recycled content.



**VOC Emissions**  
Less than 0.02mg/sqm/hr (ASTM D5116).



**Features**  
Formaldehyde-free, impact-resistant, humidity and moisture resistant, compatible with TextileSafe™ anti-microbial treatment.



**Density**  
2000gm/sqm, lightweight yet durable.



**Installation**  
Easy to install, versatile for various indoor applications.



**Lead Time**  
Standard stock products or cut-to-order within 2 weeks, manufactured locally in Australia.



## Environmental Commitment

Blue Ink Group is deeply committed to environmental responsibility. Our AcoustIQ panels utilise recycled PET, significantly reducing landfill waste and contributing positively to environmental sustainability.

Selecting AcoustIQ supports circular economy initiatives and enhances your project's Green Star rating, underscoring your commitment to sustainable design practices.

# Sonus

SONUS panels embody refined simplicity, designed specifically for those spaces where visual clarity and acoustic precision meet.

With their solid, flat finish and clean lines, SONUS panels deliver exceptional acoustic management while effortlessly complementing a wide range of interior styles, particularly minimalist and contemporary environments where subtle sophistication is key.

- Clean, solid finishes ideal for diverse environments.
- 10mm or 20mm thickness to complement interior aesthetics.
- Exceptional acoustic control, versatile colour options, standard flat finish.
- Ideal for modern, minimalist interiors.





# Sonus

All standard sheet sizes

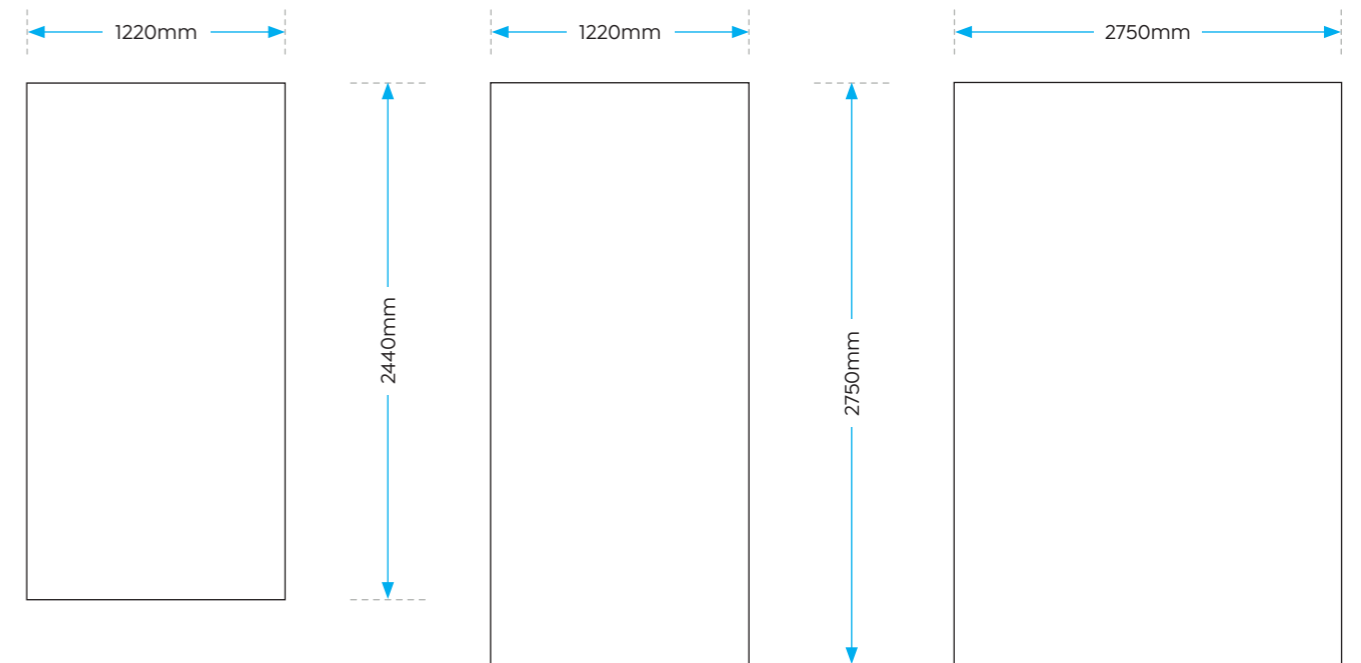

## 2-Toned Options

Taking advantage of the color variety, Sonus can be offered with multiple layered color options.

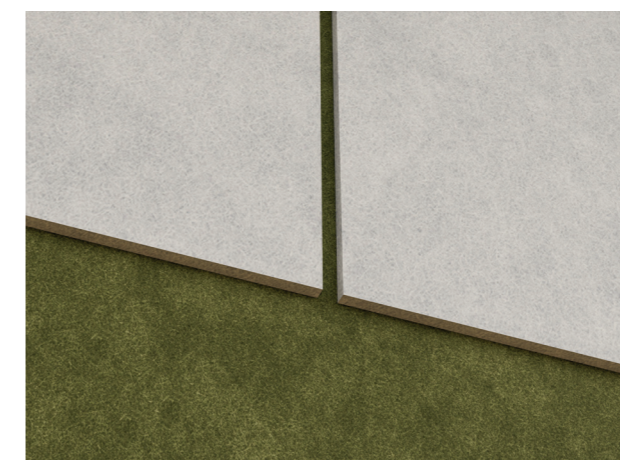

## Available Panel Thickness

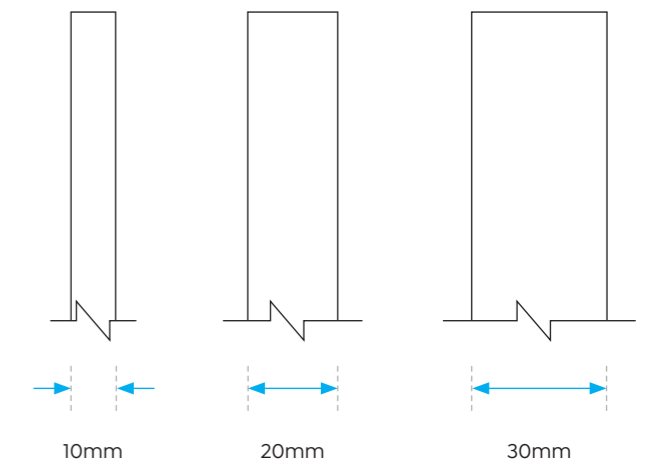

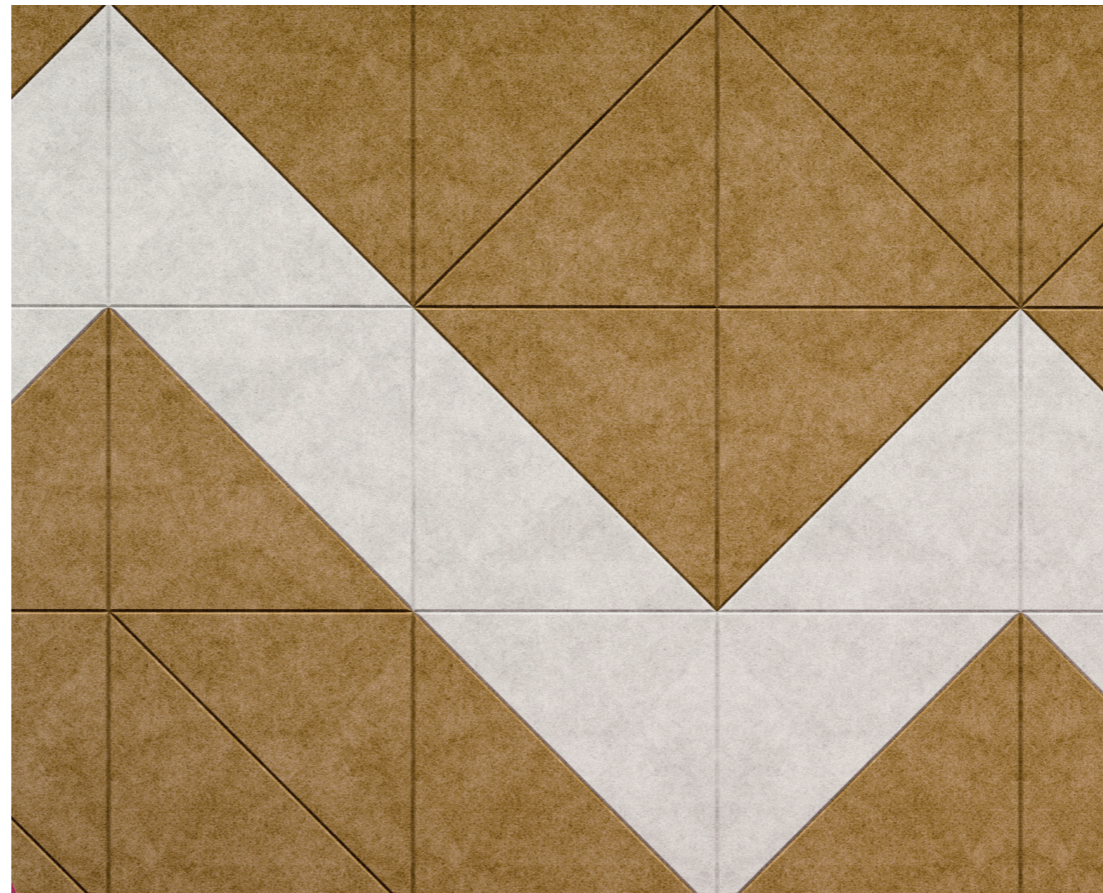

## V-Line

V-LINE panels bring precision and dynamic visual interest to your interiors.

Crafted with sharply defined V-grooves that reveal vibrant inner colours, these panels enhance both aesthetic appeal and acoustic performance. Ideal for creative spaces, boardrooms, and reception areas, V-LINE offers customisable angles and patterns, allowing designers to integrate distinctive geometric expressions into their projects.

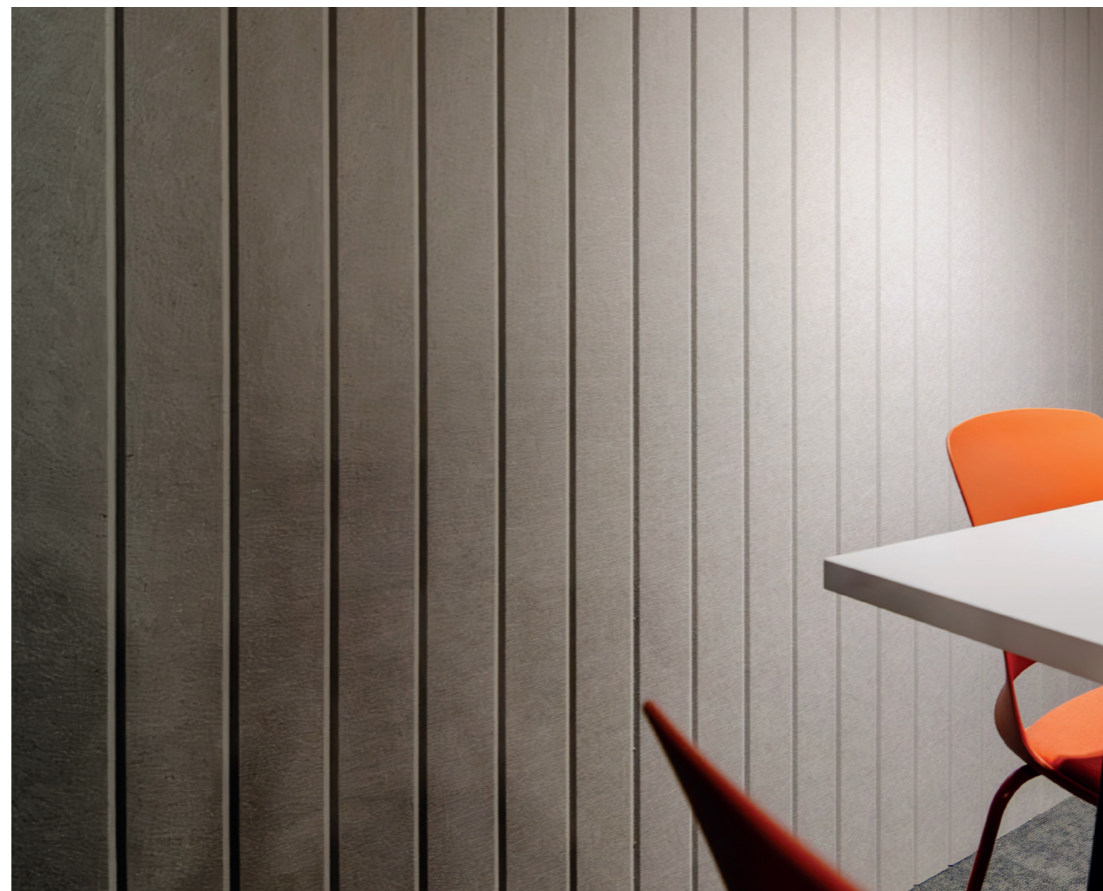

- Precision-cut V-grooves revealing inner colours.
- 20mm thickness, customisable patterns.
- Bold geometric visuals, acoustic efficiency.
- Best suited for boardrooms, receptions, creative spaces.

# V-Line

## Available V-Line Patterns

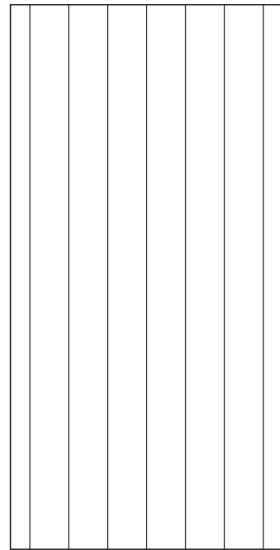

Pattern 1

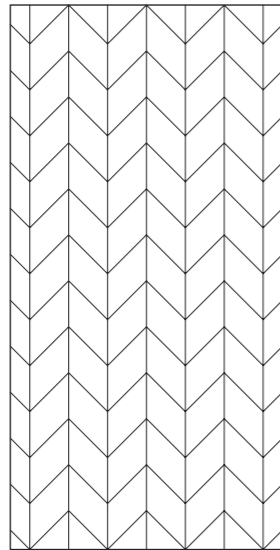

Pattern 2

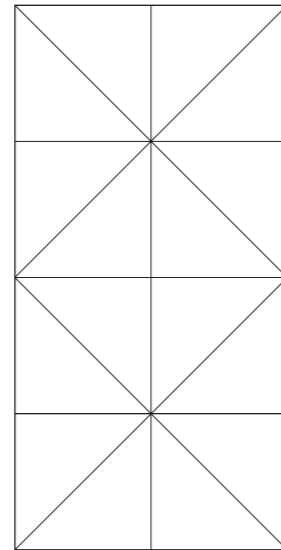

Pattern 3

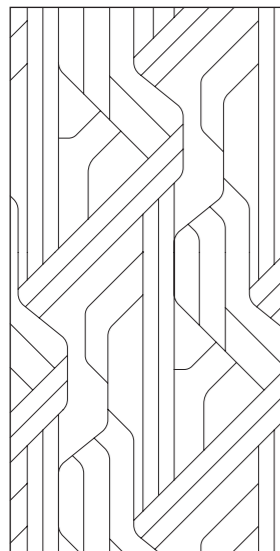

Pattern 4

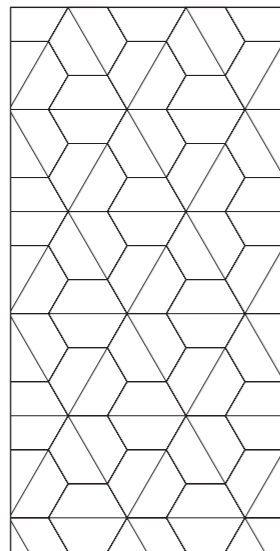

Pattern 5

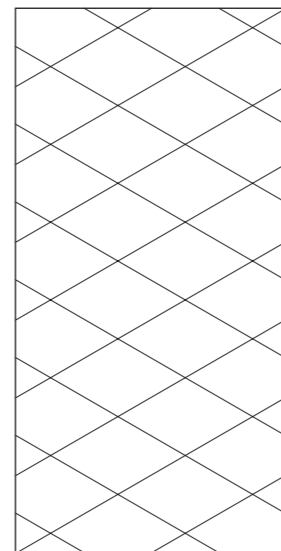

Pattern 6

## Available V-Line Groove Angles

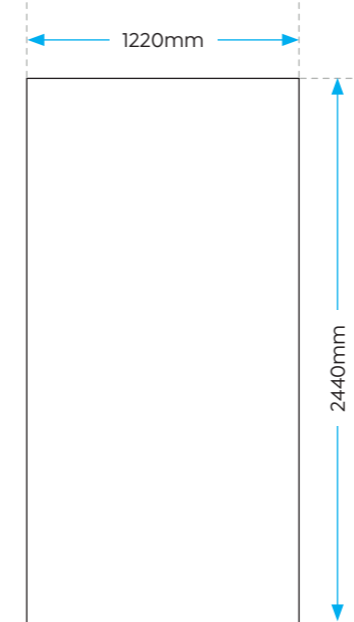
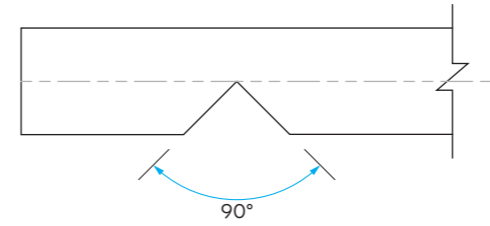

## 2-Toned Groove Cut

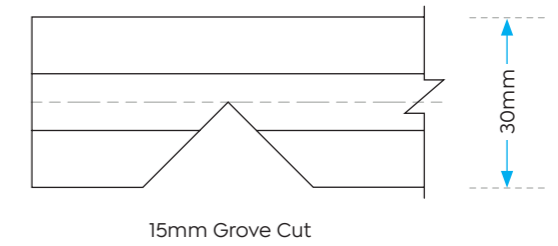

Similar to Sonus, V-Line also offers a fully customisable, multi-layer color option.



## Available Panel Thickness

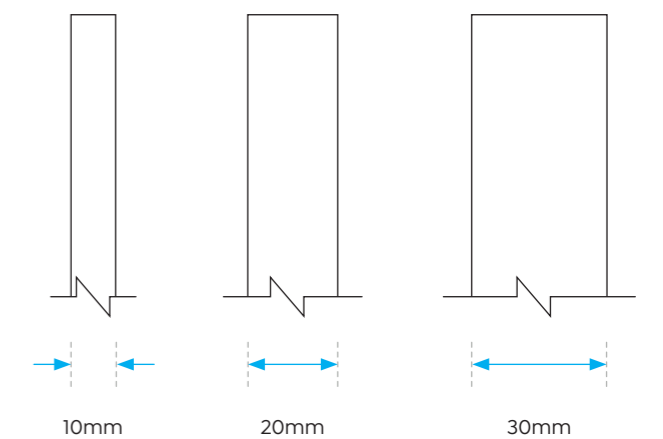

### Standard V-Line Sheet Size 1220 x 2440mm

Custom size and patterns are available, please speak to your Customer Partnership Manager or visit [blueinkgroup.com.au](http://blueinkgroup.com.au) for more information.

# Contour

CONTOUR panels introduce a graceful, fluid aesthetic that softens the acoustic and visual atmosphere of collaborative environments.

These panels feature gently undulating patterns that evoke a sense of movement and warmth, making them perfect for spaces such as lounges, meeting rooms, and breakout zones where comfort and interaction thrive.

- Clean, solid finishes ideal for diverse environments.
- Exceptional acoustic control, versatile colour options, standard flat finish.
- Multi-layers to create depth and complement interior aesthetics.
- Ideal for modern, minimalist interiors.



# Contour

Contour panels are available in a variety of stock patterns or designs and are fully customisable in size and configuration.

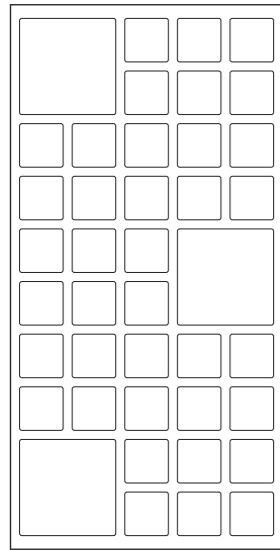

Pattern 1

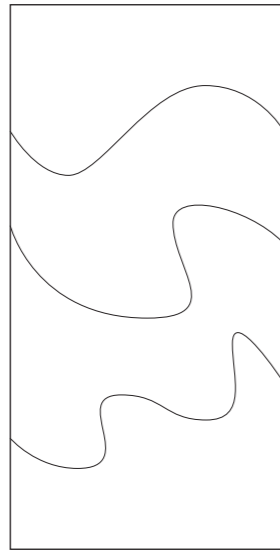

Pattern 2

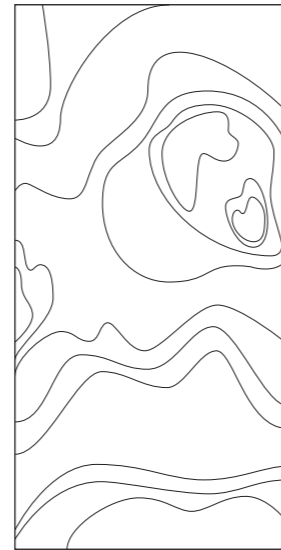

Pattern 3

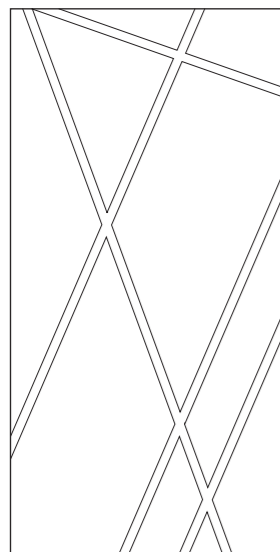

Pattern 4

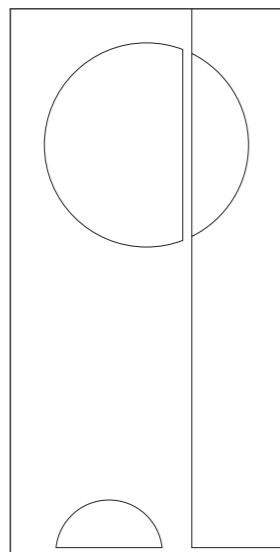

Pattern 5

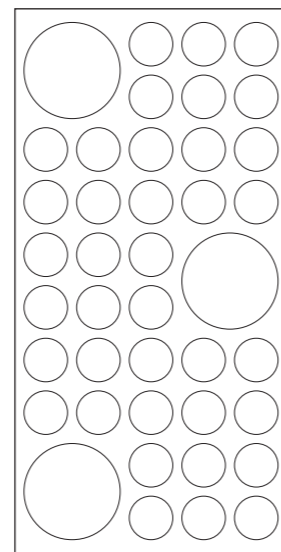

Pattern 6

## Contour Layering Details

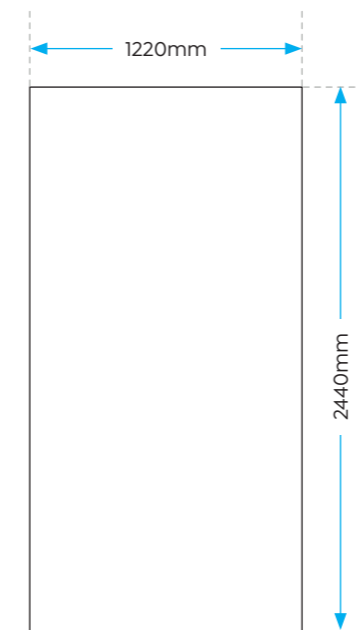
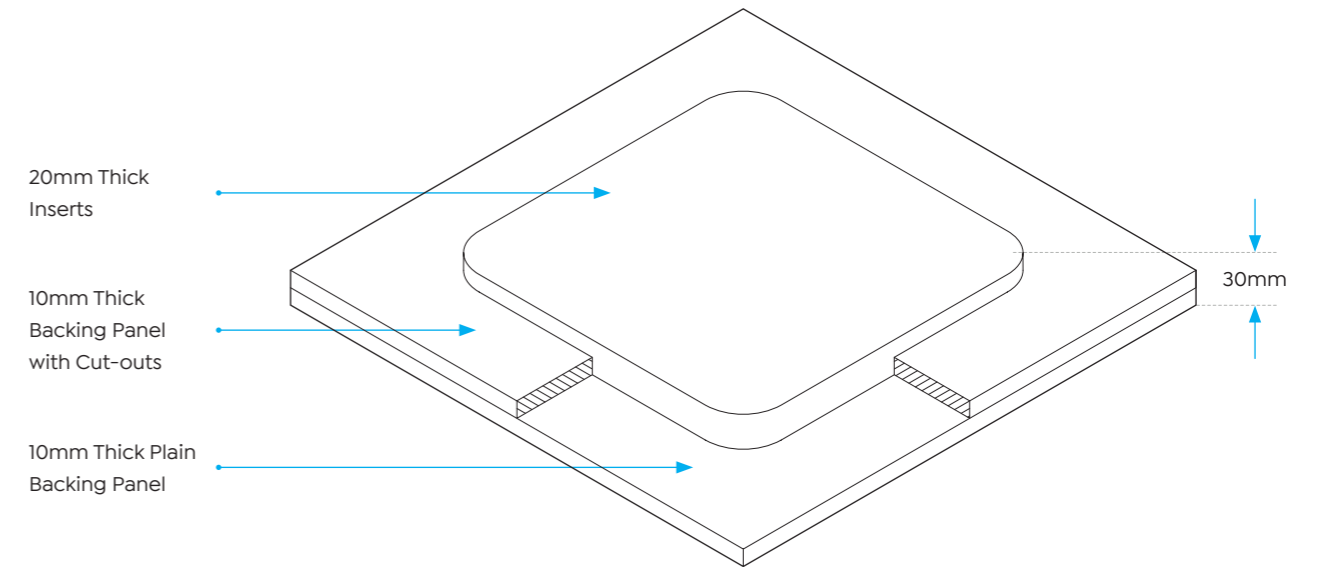

## Available Panel Thickness

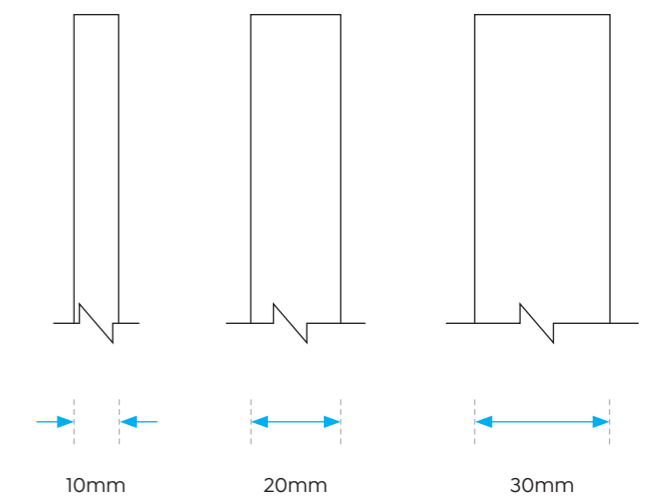

### Standard Contour Panel Sheet Size 1220 x 2440mm

Custom size and patterns are available, please speak to your Customer Partnership Manager or visit [blueinkgroup.com.au](http://blueinkgroup.com.au) for more information.

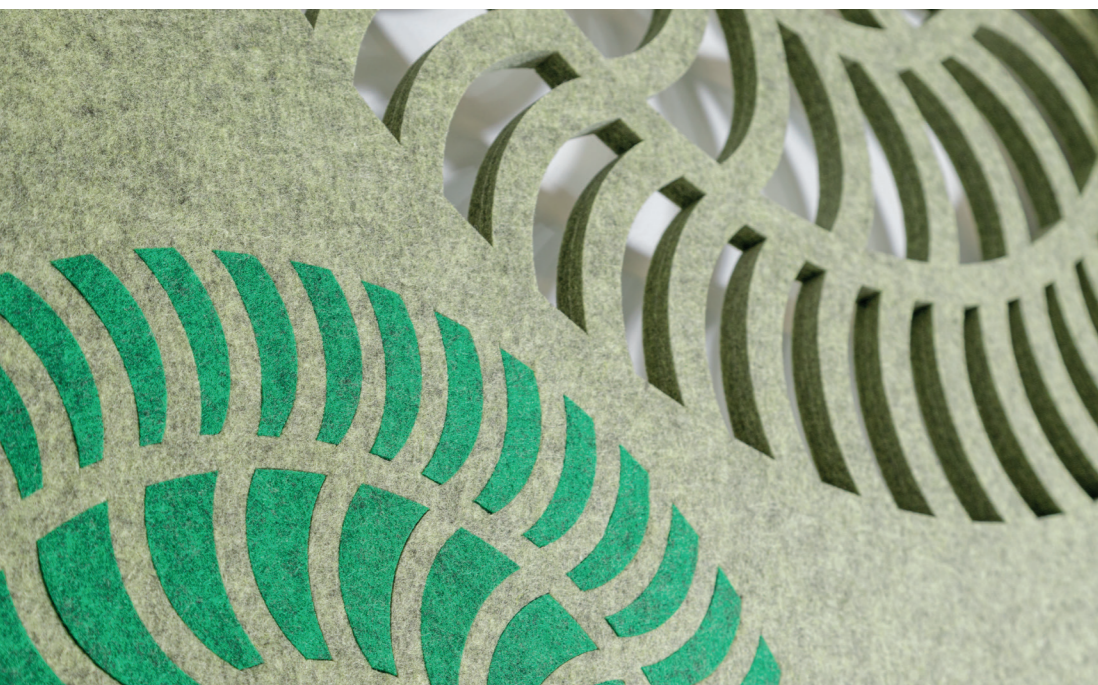
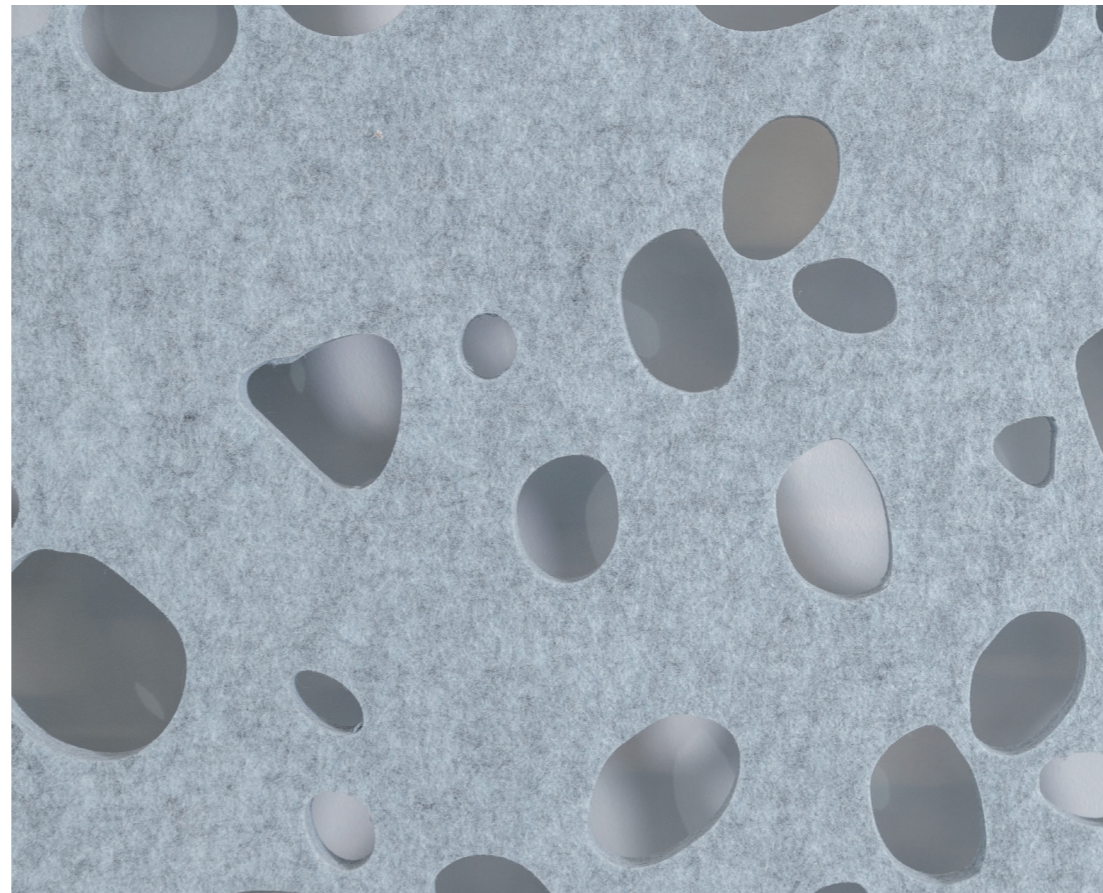

## Breeze

BREEZE panels capture the soothing essence of nature, transforming any workspace into an area of calm and tranquility.

With designs inspired by subtle natural textures and airflow patterns, these panels effectively manage acoustics while promoting relaxation and focus, ideal for quiet zones, private offices, and wellness spaces.



- Clean, solid finishes ideal for diverse environments.
- 10mm or 20mm thickness to complement interior aesthetics.
- Exceptional acoustic control, versatile colour options, standard flat finish.
- Ideal for modern, minimalist interiors.

# Breeze

Breeze panels are available in a variety of stock patterns or designs and are fully customisable in size and configuration.

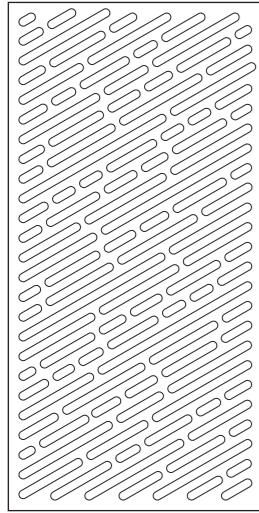

Pattern 1

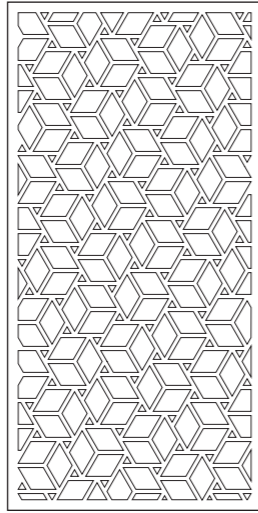

Pattern 2

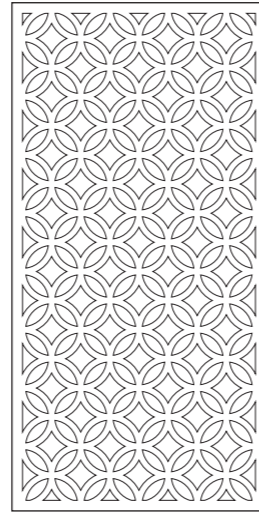

Pattern 3

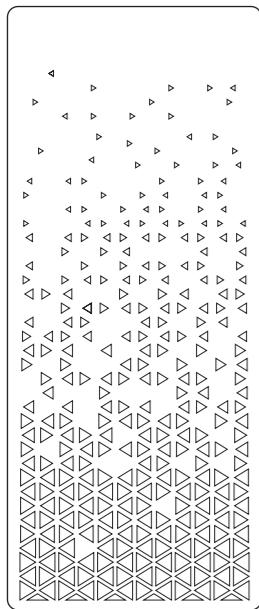
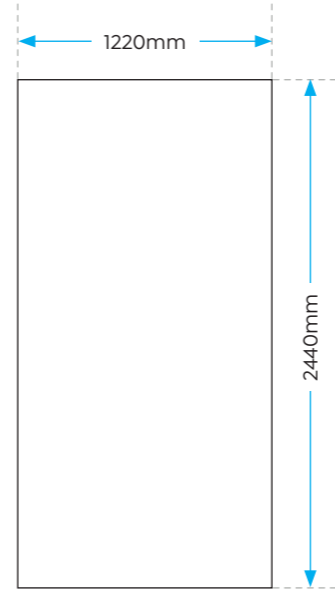

Pattern 4

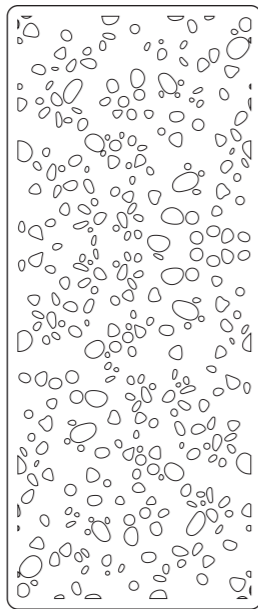

Pattern 5

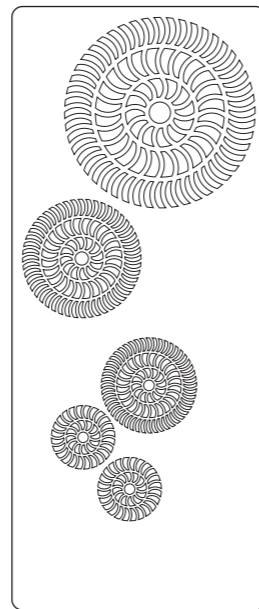

Pattern 6

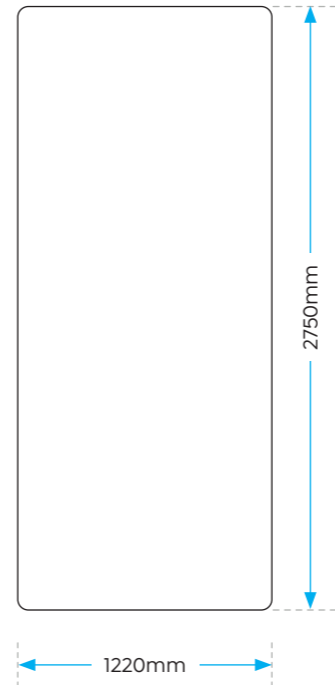

## Available Panel Thickness

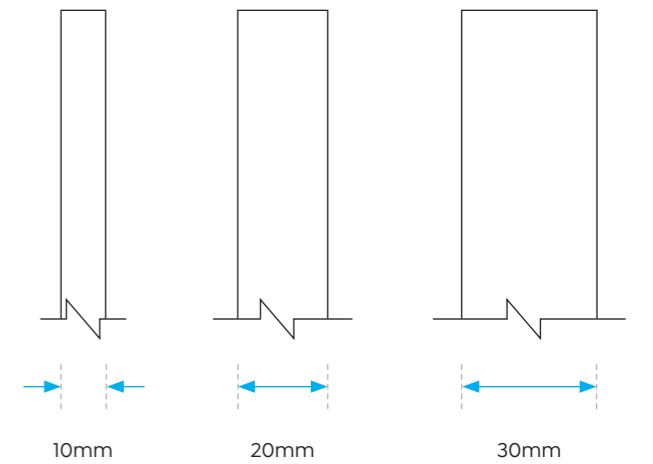

### Standard Breeze Panel Sheet Size 1200 x 2400mm

Custom size and patterns are available, please speak to your Customer Partnership Manager or visit [blueinkgroup.com.au](http://blueinkgroup.com.au) for more information.

# Nimbus

NIMBUS redefines ceiling acoustics, combining elegance and exceptional sound absorption in overhead solutions.

Available in diverse forms, including clouds, baffles, and circular shapes, NIMBUS panels are designed to provide acoustic clarity in expansive open-plan settings. With varying sizes and configurations, these ceiling solutions cater to diverse spatial needs and architectural aesthetics.

- Elegant ceiling solutions: clouds, baffles, and circles.
- Multiple sizes clearly detailed.
- Ideal for open-plan offices requiring superior overhead acoustics.



# Nimbus

## Inspiration starts here.

Nimbus reimagines ceiling acoustics with style and versatility. The shapes below are for inspiration. Custom designs, sizes, and forms are available to match your vision. Speak with your Customer Partnership Manager or visit [blueinkgroup.com.au](http://blueinkgroup.com.au) to learn more.

## Hanging Baffles

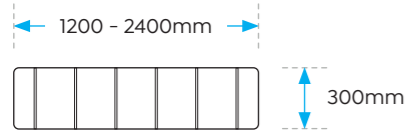
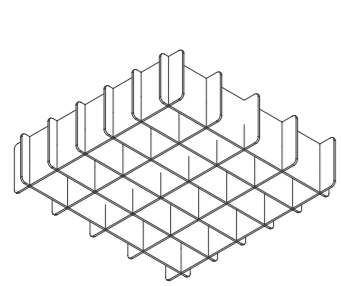

Square Baffle

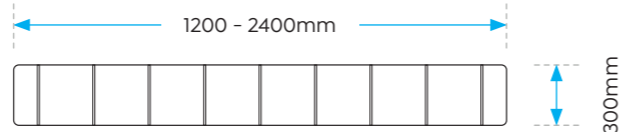
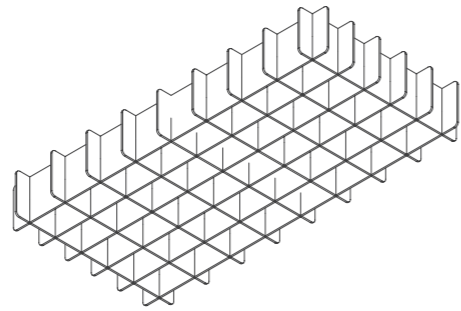

Rectangle Baffle

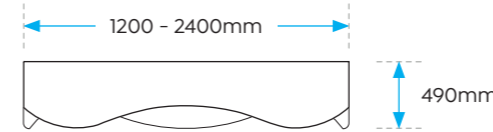
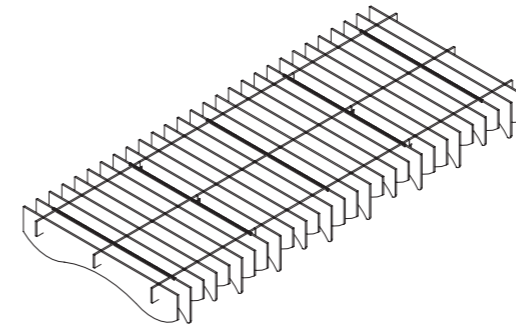

Cloud 1

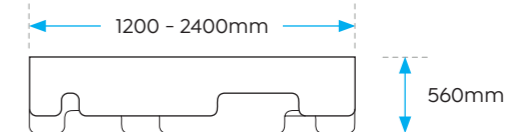
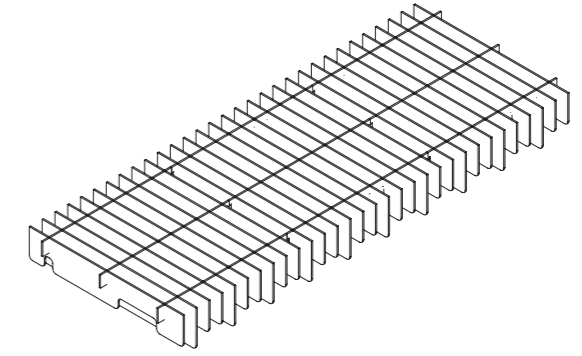

Cloud 2

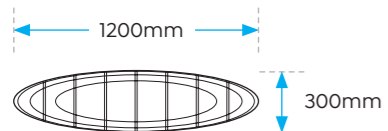
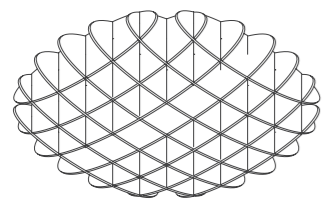

Round Baffle

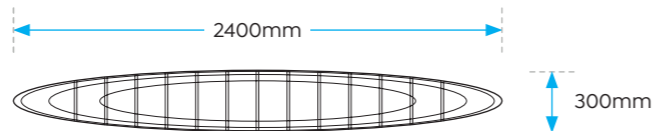
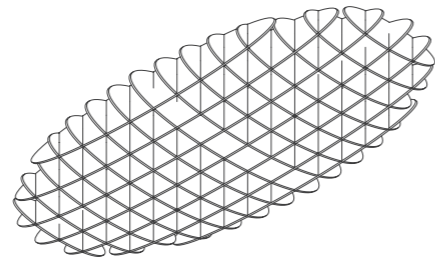

Oval Baffle

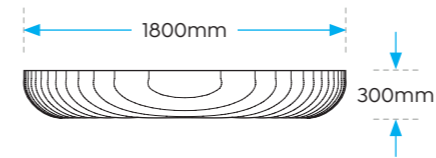
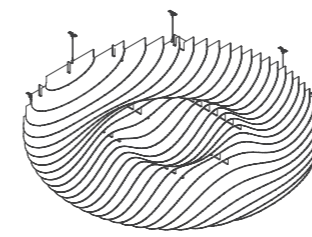

Cloud 3

## Available Panel Thickness

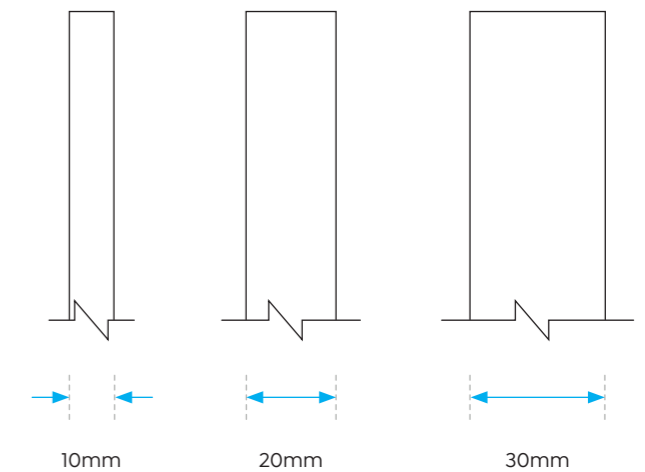



# Ceiling Tiles

Elevate your ceiling with acoustic panels that do more than just blend in.

Our flat and V-groove acoustic ceiling panels offer a refined alternative to traditional ceiling tiles—bringing enhanced sound absorption and clean architectural detail to every space. Designed to reduce reverberation while adding visual interest, these panels integrate seamlessly into standard ceiling grids.

Whether you choose the minimalist finish of flat panels or the subtle texture of V-groove designs, each solution contributes to a quieter, more design-forward environment. Ideal for modern offices, education spaces, and commercial interiors seeking both acoustic performance and elevated aesthetics.

- High acoustic performance for improved sound quality
- Seamless integration with standard ceiling grids
- Minimalist flat or textured V-groove panel options
- Ideal for workplace, education, and commercial applications
- A refined alternative to traditional ceiling tiles

# Ceiling Tiles

## Acoustic Panels, Elevated

An aesthetic and acoustic alternative to standard ceiling tiles.

### Flat

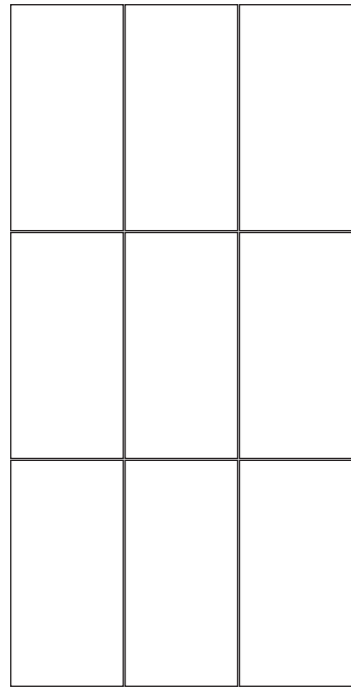

Standard Flat

### V-Line

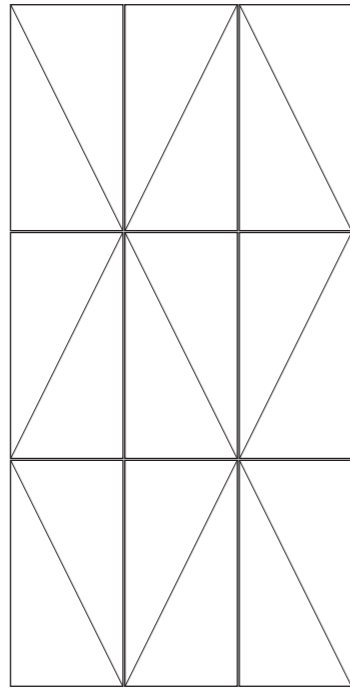

V-Line Pattern 1

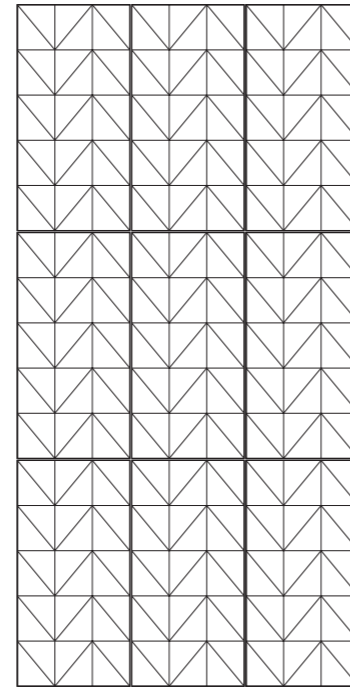

V-Line Pattern 2

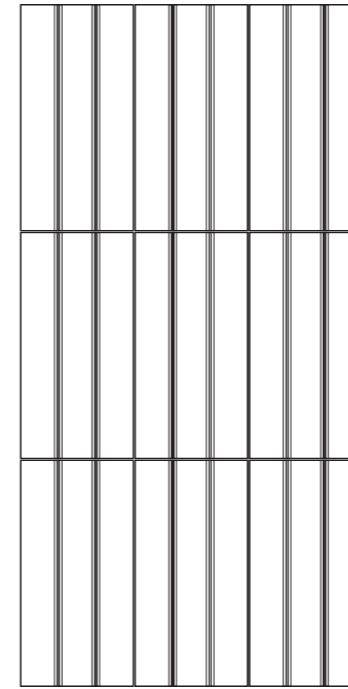

2-Tone V-Line Pattern 1

### Standard Sizes

Sold in packs of 5

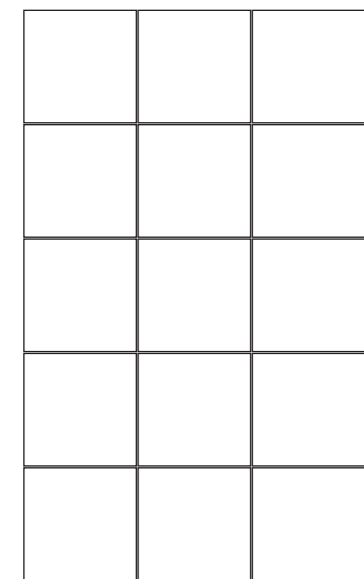
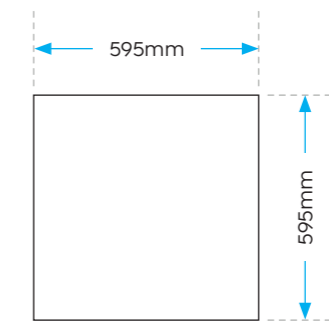
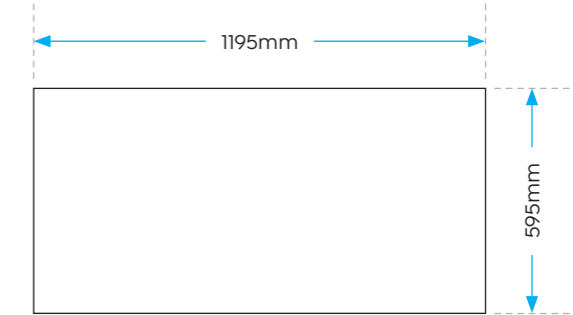

Standard Flat

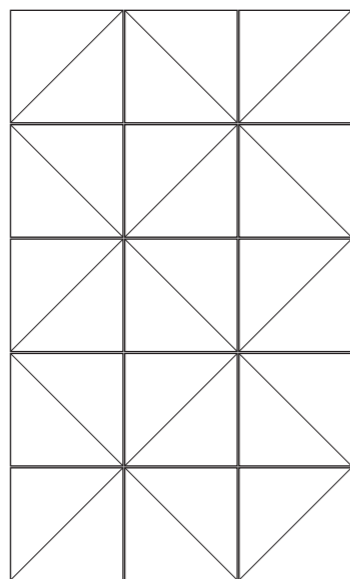

V-Line Pattern 4

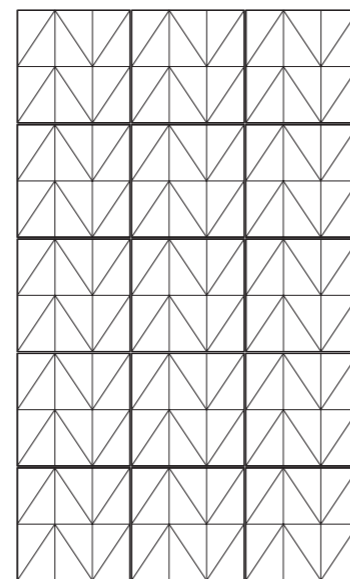

V-Line Pattern 5

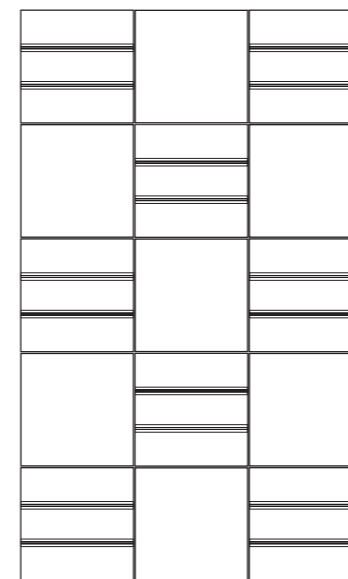

Combination of Flat & V-Line

### Available Panel Thickness

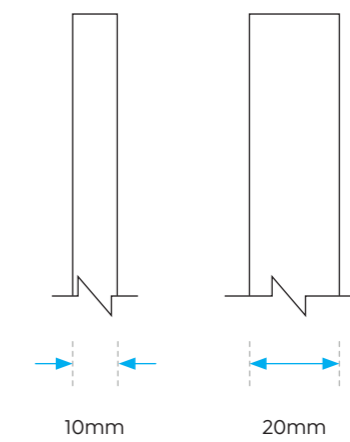

Above are some samples of the available V-Line patterns. Custom designs are also available upon request. Speak with your Customer Partnership Manager or visit [blueinkgroup.com.au](http://blueinkgroup.com.au) to learn more.

# Zen Screens

ZEN SCREENS offer adaptability and acoustic privacy tailored specifically for dynamic and agile workspaces.

Easy to install, reposition, and customise, these screens ensure immediate and flexible privacy solutions that support productivity and concentration without sacrificing style or openness.

## Zen Screens

Zen Screens introduce vibrant sophistication through dual-tone acoustic privacy panels. Designed to enhance the visual depth of interiors, these screens feature striking colour combinations that complement contemporary office aesthetics, while providing superior acoustic separation and personal privacy.

- Stylish two-tone acoustic screens.
- Enhances aesthetics and privacy.

## Zen Curved Screens

Zen Curved Screens uniquely blend soft curves and vibrant two-tone colours to elevate office aesthetics and acoustic comfort. Ideal for creating intimate, visually appealing spaces within open work environments, these screens provide effective acoustic privacy with a distinctive contemporary edge.

- Curved two-tone screens.
- Adds visual appeal and acoustic privacy.

## Zen Edge25 Screens

Stylish two-tone acoustic screens. Enhances aesthetics and privacy.

- Screen size 400mm – 2400mm x 400mm – 2400mm
- Panel thickness is 25mm



# Zen Screens

Clamp on Screens for SSD or DSD



## Brackets

Top Mounted

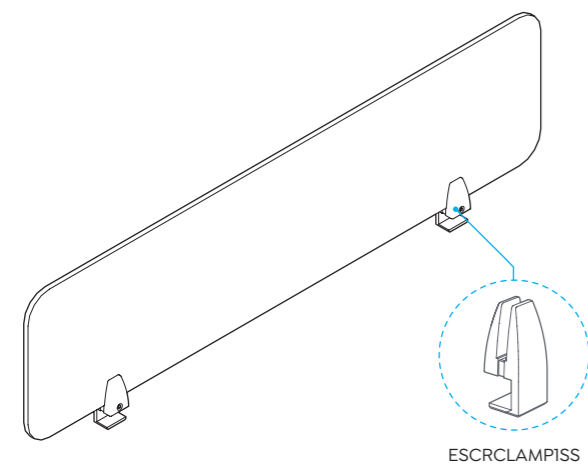

## Dimensions

Panel Thickness: 10mm & 20mm

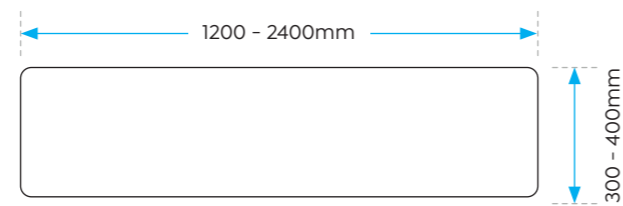

10mm Thick Panels

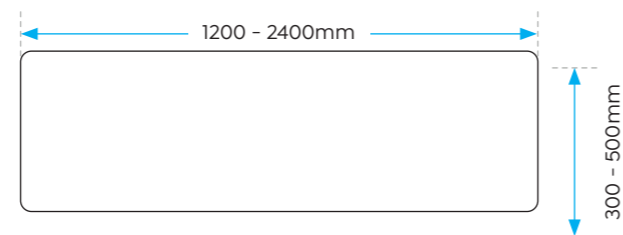

20mm Thick Panels

# Hung Screens



## Brackets

Desk Hung

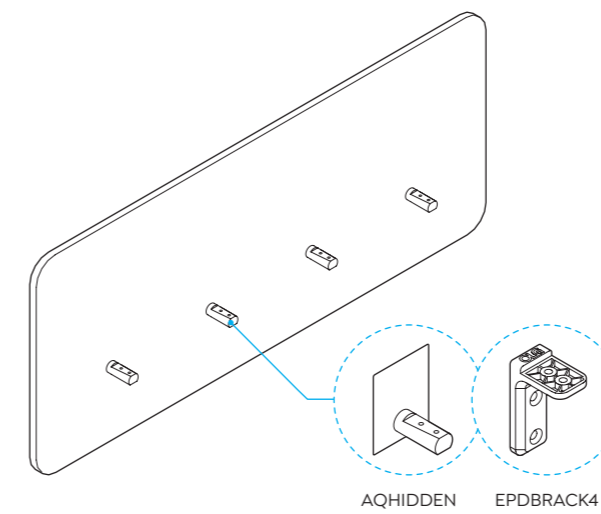

## Dimensions

Panel Thickness: 20mm

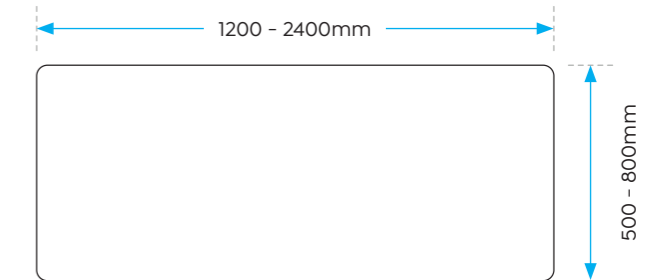

# Zen Screens

## Electric Desk Screens



### Brackets

Frame Mounted

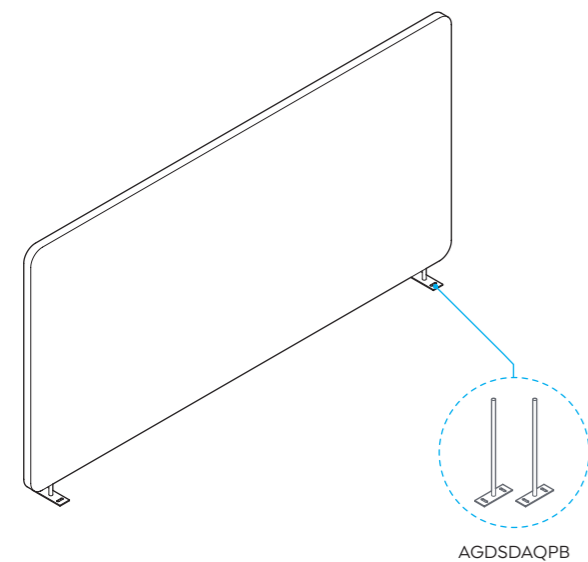

### Dimensions

Panel Thickness: 30mm

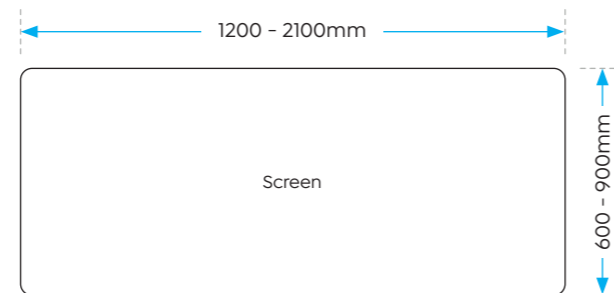

Custom sizes and shapes available.

## Single Wrap Screens



### Brackets

Desk Hung

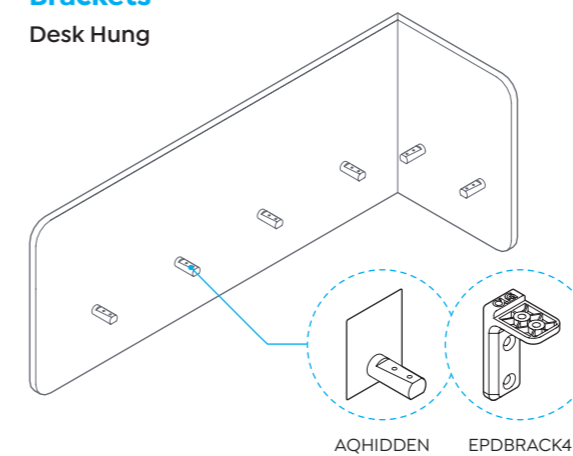

Clamp On

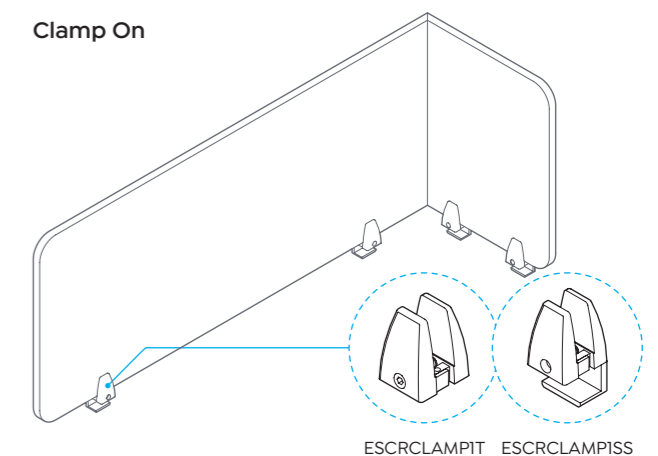

### Dimensions

Panel Thickness: 30mm

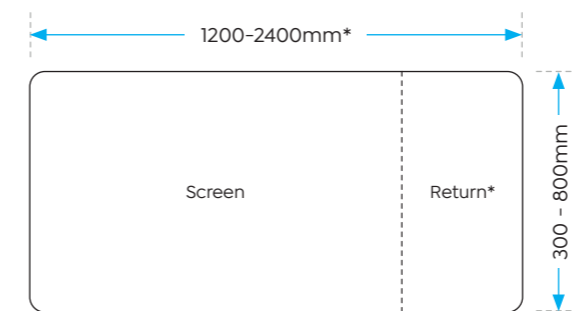

Desk Hung

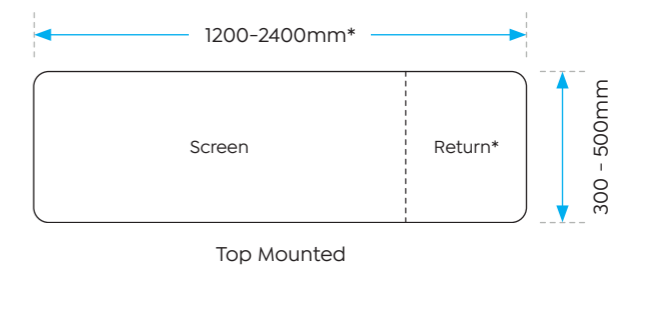

Top Mounted

\*The maximum total length is 3300mm, however this will include a join in the panel at the back of the screen.

# Zen Screens

## Double Wrap Screens



### Brackets

Desk Hung

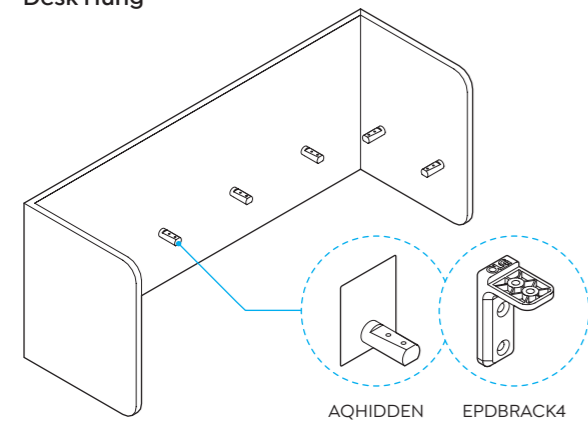

Clamp On

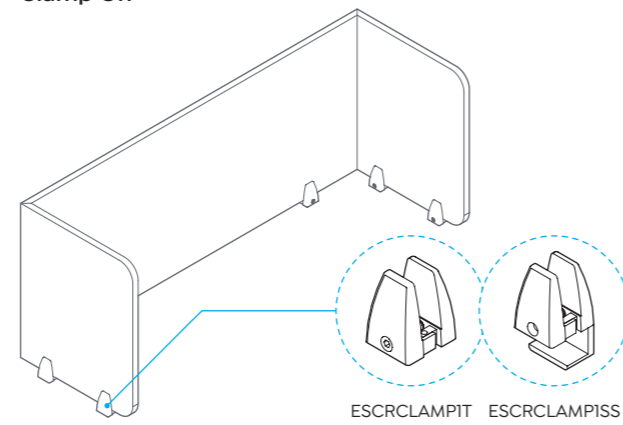

### Dimensions

Panel Thickness: 30mm

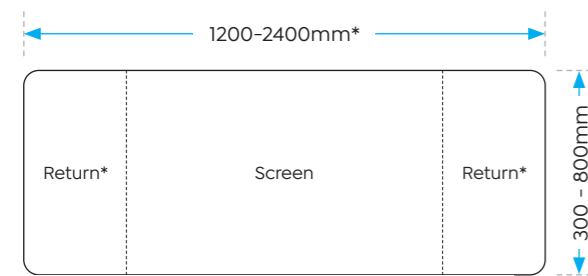

Desk Hung

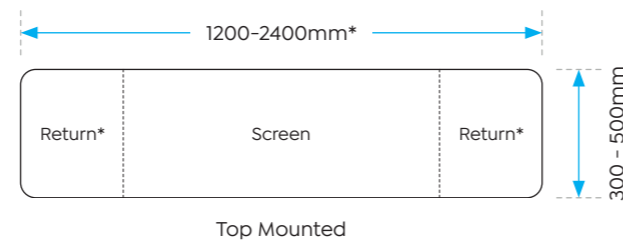

Top Mounted

\*The maximum total length is 3300mm, however this will include a join in the panel at the back of the screen

## Slide On Screens



### Dimensions

Panel Thickness: 20mm & 30mm

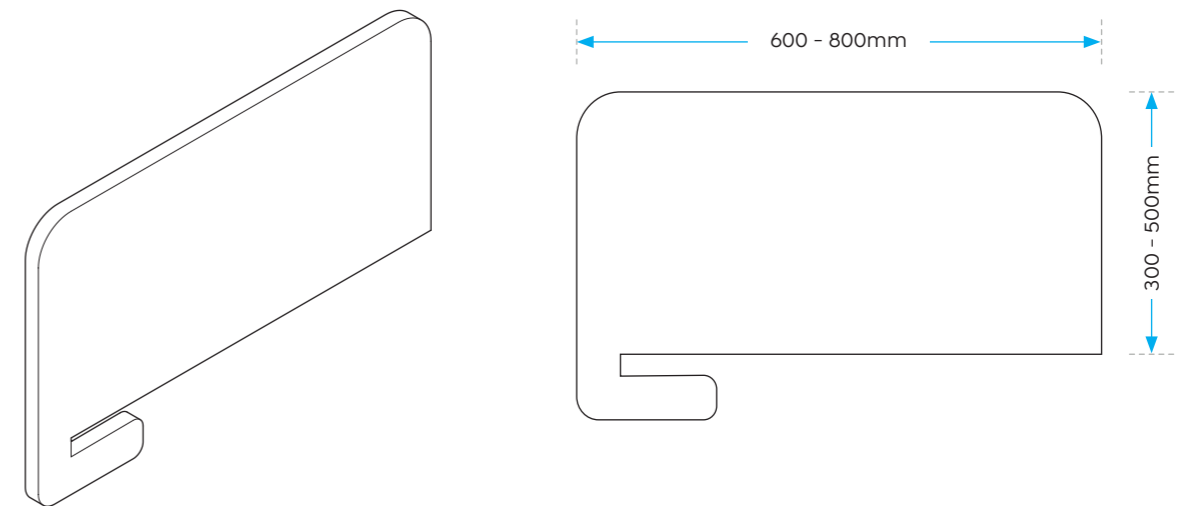

# Zen Curve Screens

## Single Wrap Screens



### Brackets

Desk Hung

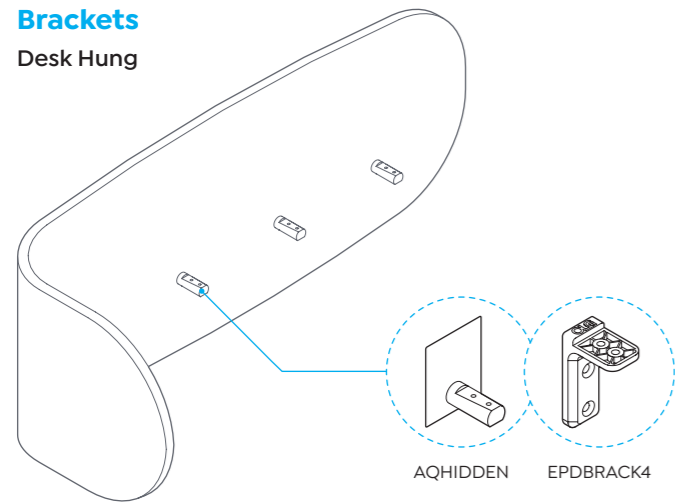

### Dimensions

Panel Thickness: 30mm

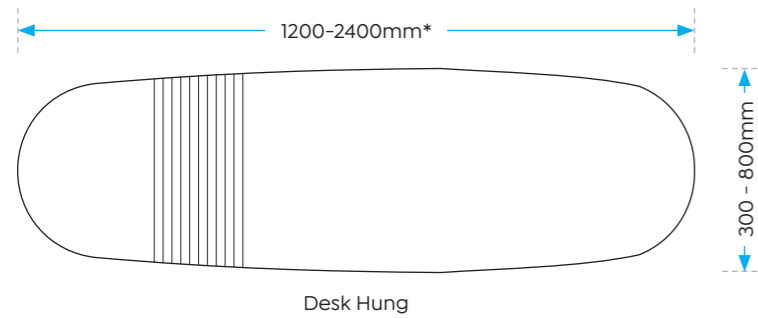

\*The maximum total length is 3300mm, however this will include a join in the panel at the back of the screen

## Single Wrap Screens



### Brackets

Desk Hung

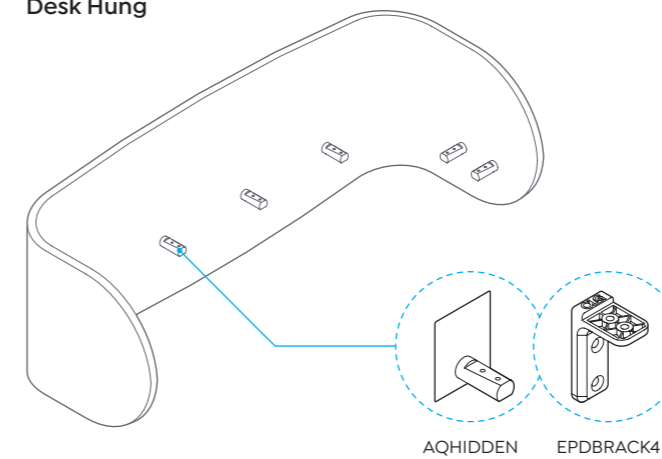

### Dimensions

Panel Thickness: 30mm

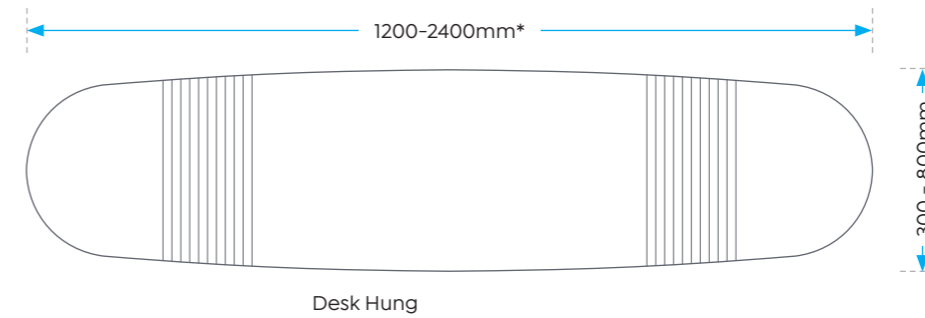

\*The maximum total length is 3300mm, however this will include a join in the panel at the back of the screen

# Zen Edge25 Screens

## Frame Mounted Screens



### Brackets

Frame Mounted

### Dimensions

Standard sheet size

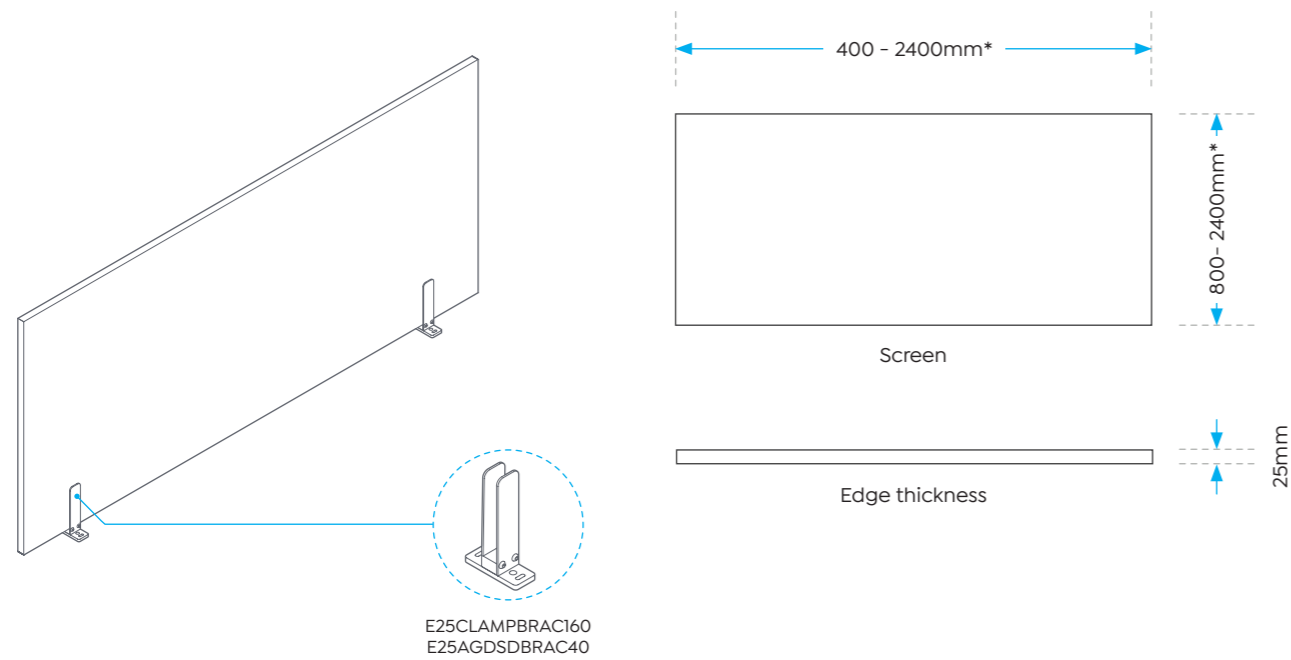

\*Edge25 screens can range from 400 mm to 2400 mm in both width and height, depending on your needs.

## Floor Mounted Screens



### Brackets

Floor Mounted

### Dimensions

Standard sheet size

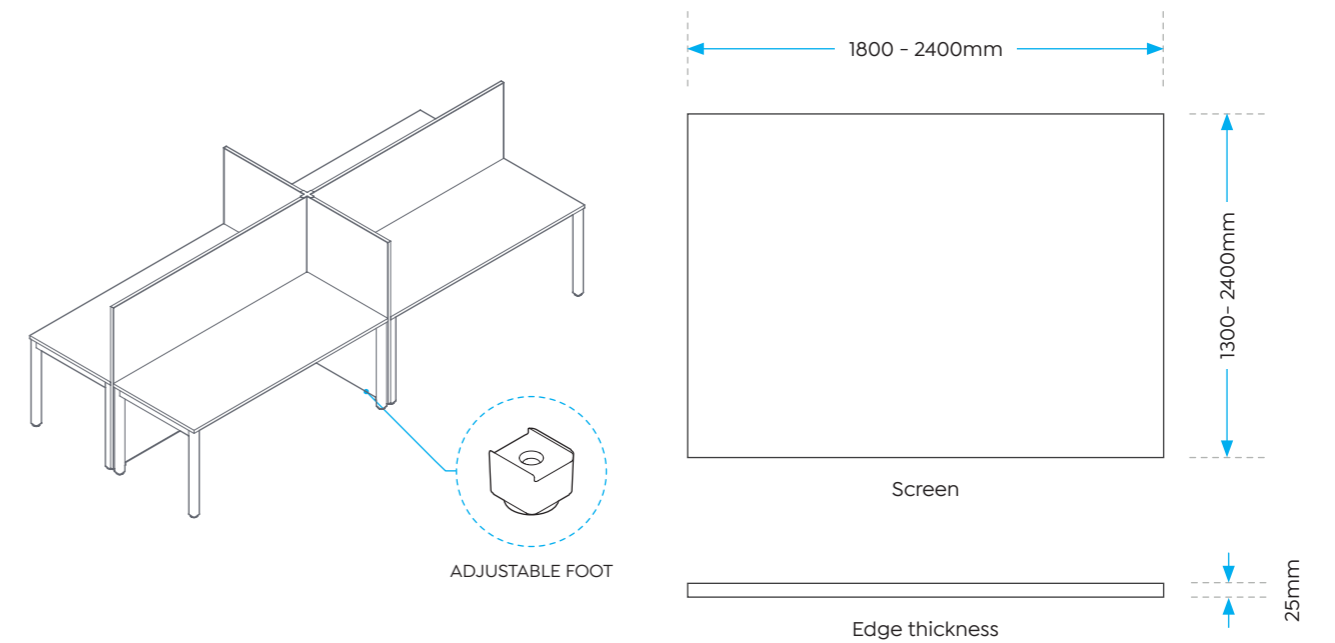

\*Edge25 screens can range from 400 mm to 2400 mm in both width and height, depending on your needs.

# Zen Edge25 Screens

## Free Standing Screens

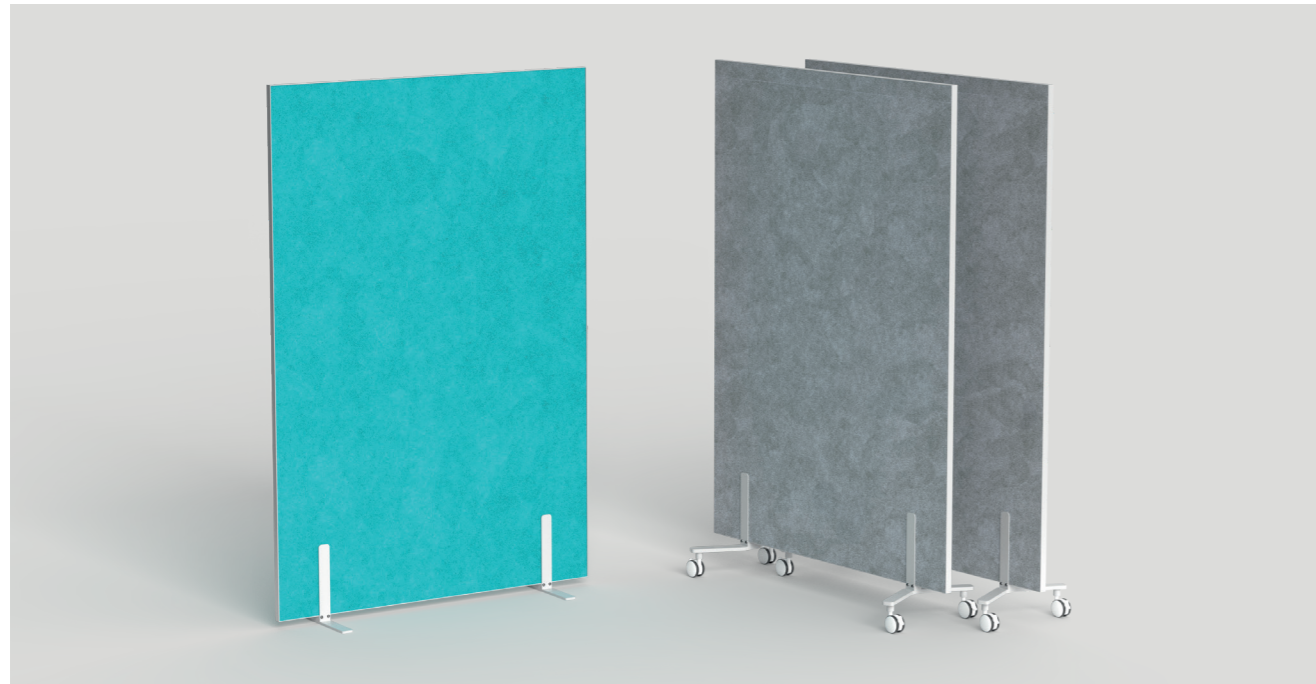

### Brackets

Free Standing Mobile or Fixed

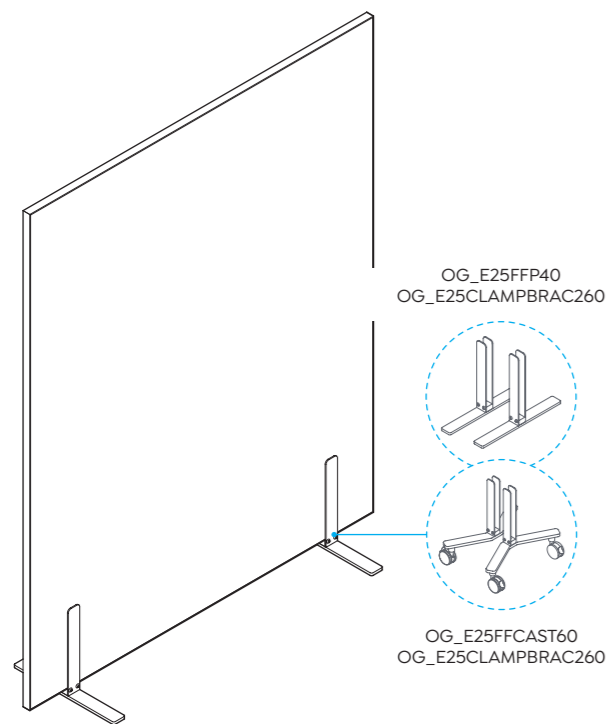

### Dimensions

Standard sheet size

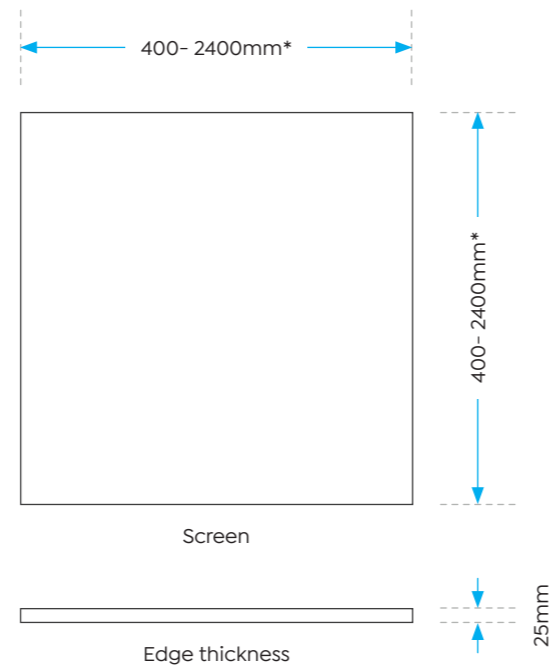

\*Edge25 screens can range from 400 mm to 2400 mm in both width and height, depending on your needs.

## Desk Mounted Screens



### Brackets

Desk Mounted

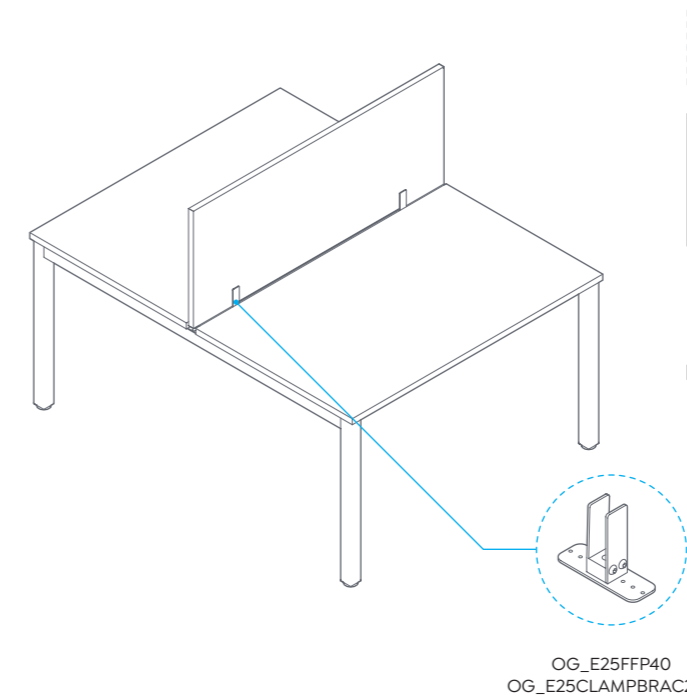

### Dimensions

Standard sheet size

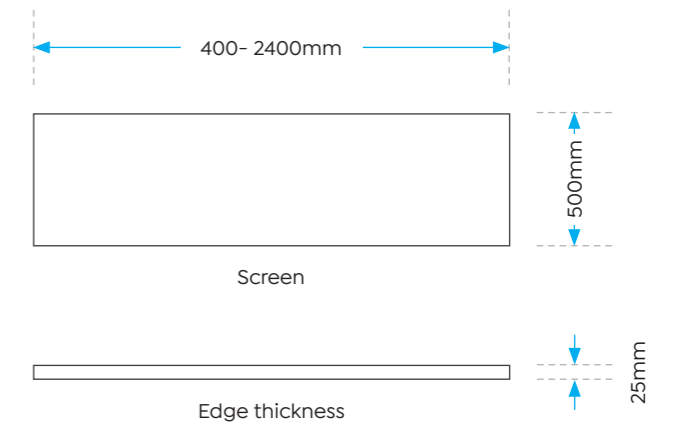

\*Edge25 screens can range from 400 mm to 2400 mm in both width and height, depending on your needs.



# Mosaic

MOSAIC panels deliver intricate artistry coupled with exceptional acoustic management, perfect for spaces seeking a visual statement.

Featuring detailed V-groove designs, these panels function as both acoustic control elements and decorative centrepieces, ideal for prominent spaces like feature walls, reception areas, or any environment where design impact is paramount.

Available patterns in stock

In pack of 24

Includes adhesive backing



10mm square tiles



10mm crescent tiles

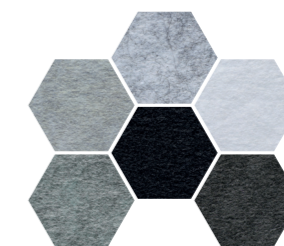

10mm hexagon tiles

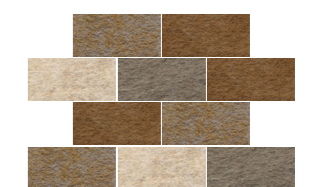

10mm plank tiles

- Intricate, artistic V-groove patterns.
- Combines visual impact with acoustic performance.
- Ideal for feature walls and design-driven interiors.

# Unique Printed Panels

## Design That Performs

Transform your interiors with Blue Ink Group AcoustiQ custom print panels, where acoustic performance meets personalised design. Using advanced digital printing, we bring your vision to life, whether replicating wood finishes, showcasing artwork, or matching brand colours. Ideal for boardrooms, receptions, and feature walls, these decorative panels combine aesthetics with functionality.

The print process does not affect acoustic properties, and the fade-resistant finish ensures lasting impact. Easy to install, custom print panels add a unique visual dimension while enhancing acoustic comfort in any space.

- High Acoustic Performance – Printed panels maintain their sound-absorbing properties.
- Fade-Resistant Finish – Durable prints that stand the test of time.
- Use Your Own Image – Or select from a wide range of high-quality imagery.

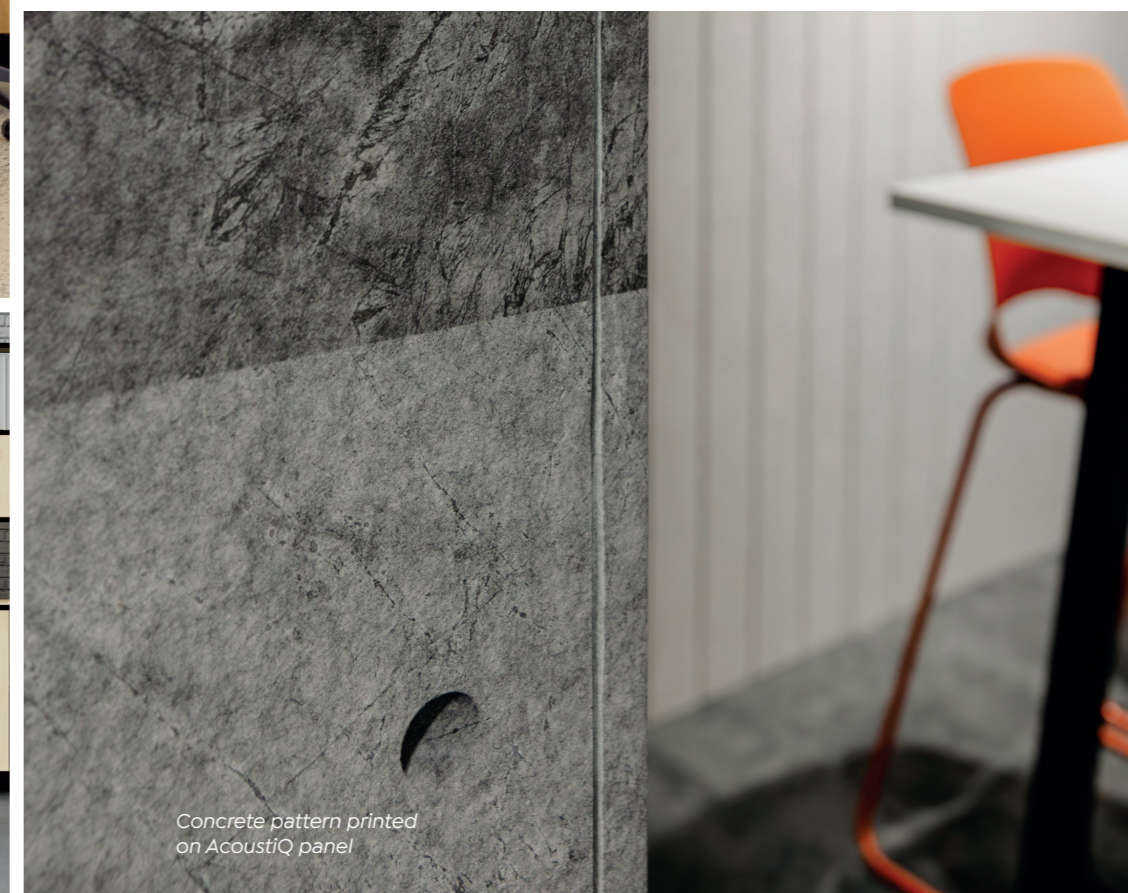

# Custom Print Panels

Our custom print panels transform entrances and feature walls into bold design statements, helping bring your vision to life. The images below are for inspiration only. Custom prints are available upon request.

Please speak to your Customer Partnership Manager or visit [blueinkgroup.com.au](http://blueinkgroup.com.au) to learn more information.



Wood Grain



Wood Siding



Custom Doodle Art Patterns



Photography

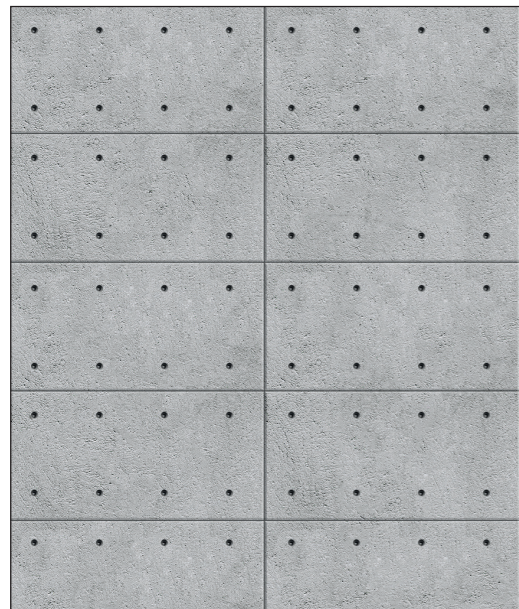

Concrete

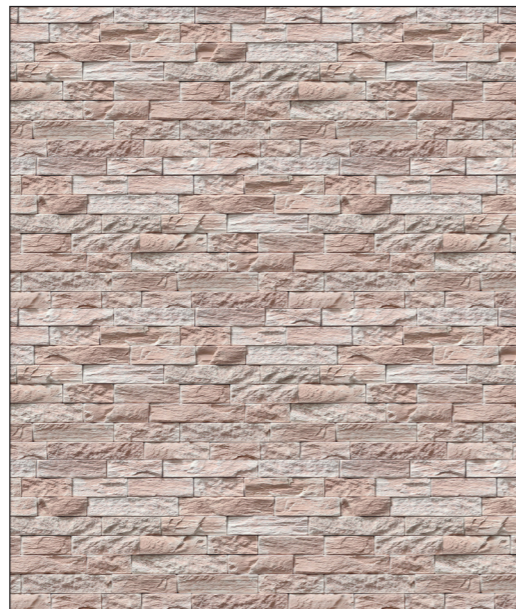

Stone Brick















































Vector Patterns



Photography

# Colour Options

AcoustIQ offers an extensive palette from neutral shades to vibrant hues, enabling tailored aesthetics to complement any interior design vision.

<b>Marble</b>	 Dark Red	 Burnt Orange	 Marble Grey	 Pacific Marble	 Moss Banana Green	
<b>Forest</b>	 Dark Green	 Light Fern	 Fern	 Dark Fern	 Banana Green	 Golden Yellow
<b>Neutrals</b>	 Black	 Charcoal Grey	 Grey	 Slate Grey	 White	 Light Merlot
	 Light Beige	 Natural	 Dark Beige	 Mid Natural	 Dark Natural	 Brown
<b>Jewel</b>	 Dark Purple	 Dark Blue	 Dark Peacock Green	 Indigo Blue	 Dark Merlot	 Merlot
	 Maroon	 Dark Maroon	 Peacock Green	 Pacific Blue		
<b>Bright &amp; Bold</b>	 Green	 Cobalt Blue	 Sky Blue	 Purple	 Blue	 Red
	 Royal Pink	 Pink	 Coral Pink	 Orange	 Yellow	

Colours are shown as accurately as possible for digital and print but may differ from the actual. Use as a guide only.

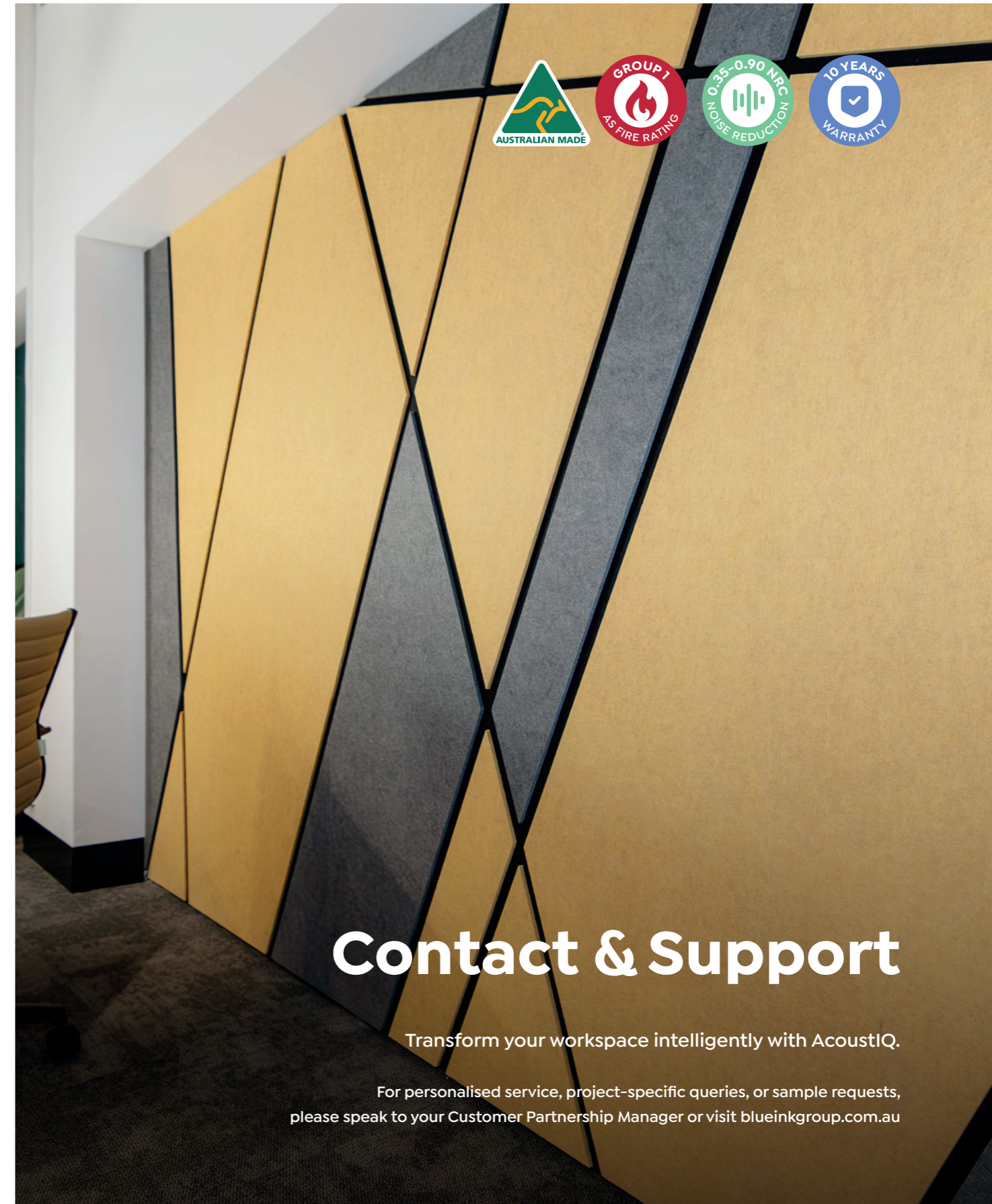



176-178 Gladstone Street Fyshwick ACT 2609 Australia

Canberra: (02) 6166 6000 Sydney: (02) 9308 6006

Email: [sales@blueinkgroup.com.au](mailto:sales@blueinkgroup.com.au)

[www.blueinkgroup.com.au](http://www.blueinkgroup.com.au)